

SCAFFOLDS

Temporary elevated work platforms

GUIDELINES FOR OREGON WORKERS

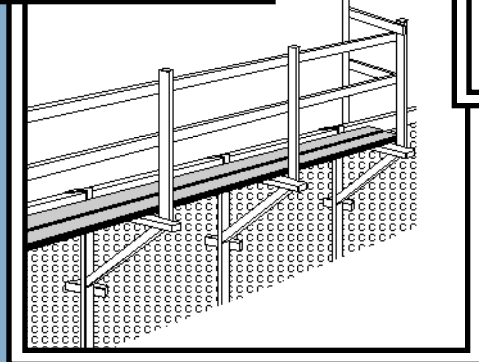
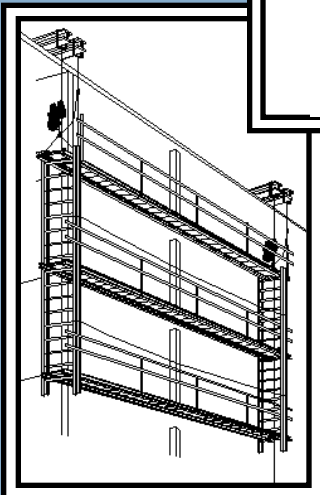
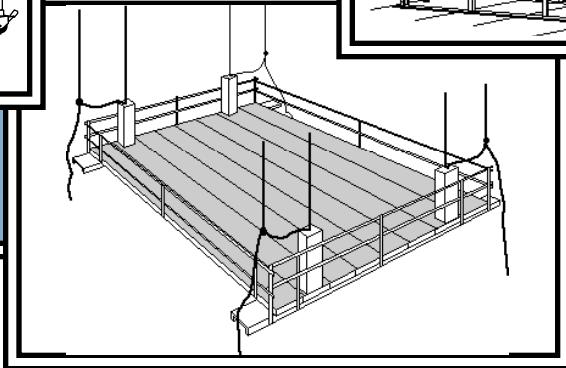
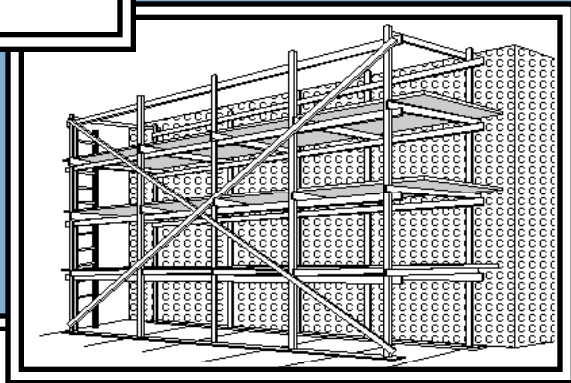
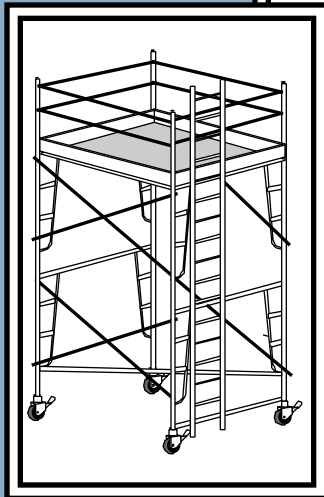
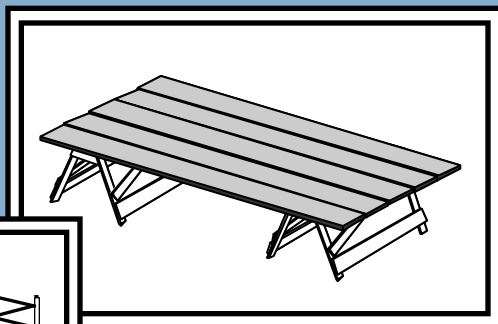

Contents

	Page
Introduction	1-2
The purpose of this guidebook	
The scaffold as a temporary work platform	
A quick tour of Subdivision 3/L	
Definitions	3-10
Competent person	
Qualified person	
Working safely on scaffolds	11-21
Scaffold capacities	
Platform construction	
Access to scaffolds	
Protecting workers from falling objects	
Protecting workers from falling	
Safe work practices	
Safe practice checklist	
Types of scaffolds and lifts	23-34
Supported scaffolds	
Suspension scaffolds	
Aerial lifts	
Training requirements	35
Training guidelines	37
Handling emergencies	39



In compliance with the Americans with Disabilities Act (ADA), this publication is available in alternative formats.

Call the OR-OSHA public relations manager at (503) 378-3272 (V/TTY).

Materials contained in this publication are in the public domain and may be copied and distributed without permission from Oregon OSHA.

The purpose of this guidebook

We created this guidebook to help you design, construct, and use scaffolds safely. The guide highlights Oregon OSHA's scaffold requirements for the construction industry, Subdivision 3/L of the construction safety and health rules. The guide also identifies unsafe work practices and shows most types of scaffolds used in construction work. Use this guide as a supplement to Subdivision 3/L, not as substitute. You should become familiar with Subdivision 3/L before you do any work involving scaffolds. To get a copy contact the OR-OSHA Resource Center, (800) 922-2689, Fax (503) 947-7463, or visit our Web site www.orosha.org.

The scaffold as a temporary work platform

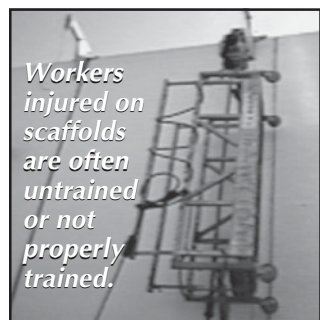

A scaffold is a temporary elevated platform that supports workers and materials, and almost anyone can build a structure that satisfies this definition. Lay a board across whatever is convenient to reach your work and you have a scaffold. Right? Take this definition literally and you could be dead wrong.

A scaffold is actually far more than a temporary work platform. It's designed and constructed specifically so that trained workers can do their jobs safely. Unsafe scaffolds endanger workers in many ways. Components can break, collapse, or give way. Planks, boards, decks, or handrails can fail. In some cases, entire structures have collapsed. Even on sound scaffolds, workers can slip or lose their balance, and without appropriate protection, they don't have to fall far to get hurt. More often than not, scaffold accidents can be traced to untrained or improperly trained workers.

Scaffolds can be complex structures. Too often, untrained workers use makeshift staging, overload platforms, fail to inspect supports, or use scaffolds for the wrong tasks. This guidebook and Oregon OSHA's Subdivision 3/L scaffold rules can help you learn what you need to know so that a temporary work platform won't let you down.

A quick tour of Subdivision 3/L

Subdivision 3/L identifies what workers and employers need to know to use all types of scaffolds safely.

Subdivision 3/L covers all scaffolds used in construction, alteration, repair, and demolition work. Subdivision 3/L doesn't apply to crane- or derrick-suspended personnel platforms covered in Subdivision 3/N. The table on the next page shows how Subdivision 3/L is organized.

Introduction



Rule	Topics
1926.450	Scope, application, definitions
1926.451	<p>General Requirements</p> <ul style="list-style-type: none"> • Capacity • Scaffold platform construction • Supported scaffolds • Suspension scaffolds protection • Access • Use • Fall protection • Falling objects
1926.452	<p>Additional requirements for specific scaffold types</p> <ul style="list-style-type: none"> • Pole • Tube and coupler • Fabricated frame • Large area • Bricklayers' square • Horse • Form & carpenters' bracket • Roof bracket • Pump jack • Ladder jack • Window jack • Crawling boards • Trestle ladder • Single-point adjustable • Two-point adjustable • Multi-point adjustable • Catenary • Float • Interior hung • Needle beam • Multi-level suspended • Mobile • Repair bracket • Stilts
1926.453	<p>Aerial lifts</p> <ul style="list-style-type: none"> • General requirements • Specific requirements • 437-003-0071 Manually propelled elevating aerial platforms • 437-003-0073 Boom supported elevating work platforms • 437-003-0074 Self-propelled elevating work platforms
1926.454	<p>Training requirements</p> <p>All workers - qualified person Erectors & dismantlers - competent person Retraining</p>
Non-mandatory appendices	<p>A - Scaffold specifications B - [Reserved] C - National consensus standards D - Training topics for erectors and dismantlers E - Drawings and illustrations</p>

Subdivision 3/L uses many special terms. Some of them may be new to you or might be confusing in the context of a requirement, so we've included all important terms here in alphabetical order. On Pages 9-10, you'll find detailed information on two particularly important terms, the **competent person** and the **qualified person**.

These terms are also defined in Subdivision 3/L, 1926.450(b).

Adjustable suspension scaffold: A suspension scaffold with a hoist (or hoists) operated by workers on the scaffold.

Bearer: A horizontal transverse scaffold member, upon which the scaffold platform rests, that joins scaffold uprights, posts, and poles.

Boatswain's chair: A single-point adjustable suspension scaffold consisting of a seat or sling that supports one person in a sitting position.

Body harness: Straps that can be secured about the worker to distribute fall-arrest forces over the thighs, pelvis, waist, chest, and shoulders.

Brace: A rigid connection that holds one scaffold member in a fixed position with respect to another member, building, or structure.

Bricklayer's square scaffold: A supported scaffold made of framed squares that supports a platform.

Carpenter's bracket scaffold: A supported scaffold consisting of a platform supported by brackets attached to a building or structural walls.

Catenary scaffold: A suspension scaffold consisting of a platform supported by two horizontal and parallel ropes attached to structural members of a building or other structure.

Chimney hoist: A multi-point adjustable suspension scaffold that provides access for working inside chimneys. See "multi-point adjustable suspension scaffold."

Cleat: A structural block used at the end of a platform to prevent the platform from slipping off its supports. Cleats also provide footing on sloped surfaces such as crawling boards.

Competent person: One who can identify hazardous working conditions and who has authorization to take prompt corrective measures to eliminate them. For more information on the competent person, see Page 9.

Definitions

Definitions

Continuous-run scaffold (run scaffold): A two-point or multi-point adjustable suspension scaffold made from braced scaffold members or supporting structures that form a continuous scaffold.

Coupler: A device that locks together the tubes of a tube-and-coupler scaffold.

Crawling board (chicken ladder): A supported scaffold consisting of a plank with cleats spaced and secured to provide footing.

Deceleration device: Any mechanism that dissipates energy during a fall arrest or limits the energy imposed on a worker during fall arrest.

Double pole (independent pole) scaffold: A supported scaffold consisting of a platform resting on bearers supported by ledgers and a double row of uprights not supported (except with ties, guys, braces) by any other structure.

Equivalent: Alternative designs, materials, or methods that the employer can demonstrate will provide an equal or greater degree of safety for workers than the methods, materials, or designs specified in a standard.

Exposed power lines: Unshielded electrical power lines that could contact workers. Exposed power lines do not include extension cords or power-tool cords.

Eye or eye splice: A loop with or without a thimble at the end of a wire rope.

Fabricated decking and planking: Manufactured platforms made of wood (including laminated wood and sawn-wood planks), metal, or other materials.

Fabricated frame scaffold (welded-tubular frame scaffold): A scaffold consisting of a platform supported on fabricated end-frames with integral posts, horizontal bearers, and intermediate members.

Failure: Breakage or separation of component parts.

Float (ship) scaffold: A suspension scaffold consisting of a braced platform resting on two parallel bearers and hung from overhead supports by fixed-length ropes.

Form scaffold: A supported scaffold consisting of a platform supported by brackets attached to formwork.

Guardrail system: A vertical barrier consisting of top rails, midrails, and posts. Prevents workers from falling to lower levels.

Definitions

Hoist: A manual or power-operated mechanical device that raises or lowers a suspended scaffold.

Horse scaffold: A supported scaffold consisting of a platform supported by construction horses (sawhorses). Horse scaffolds made of metal are also called trestle scaffolds.

Independent pole scaffold: See “double pole scaffold.”

Interior hung scaffold: A suspension scaffold consisting of a platform suspended from a ceiling or roof structure by fixed length supports.

Ladder jack scaffold: A supported scaffold consisting of a platform resting on brackets attached to ladders.

Ladder stand: A mobile, fixed-size, self-supporting ladder consisting of a wide, flat tread ladder in the form of stairs.

Landing: A platform at the end of a flight of stairs.

Large area scaffold: A pole scaffold, tube and coupler scaffold, systems scaffold, or fabricated frame scaffold erected over an entire work area.

Lean-to scaffold: A supported scaffold that is kept erect by tilting toward and resting against a building or structure.

Lifeline: A flexible line that connects to an anchorage at one end and hangs vertically (vertical lifeline), or that connects to anchorages at both ends and stretches horizontally (horizontal lifeline); it connects other components of a personal fall arrest system to the anchorage.

Lower levels: Areas below the working level. Examples: ground levels, floors, roofs, ramps, runways, excavations, pits, tanks, materials, water, and equipment.

Mason’s adjustable supported scaffold: See “Self-contained adjustable scaffold.”

Mason’s multi-point adjustable suspension scaffold: A continuous-run suspension scaffold designed and used for masonry work.

Maximum intended load: The total load of all persons, equipment, tools, materials, transmitted loads, and other loads applied to a scaffold or scaffold component.

Mobile scaffold: A portable caster or wheel-mounted supported scaffold.

Multi-level suspended scaffold: A two-point or multi-point adjustable suspension scaffold with platforms at various levels that rest on common stirrups.

Definitions

Multi-point adjustable suspension scaffold: A suspension scaffold consisting of a platform suspended by more than two ropes from overhead supports that can be raised and lowered to desired work levels. Includes chimney hoists.

Needle beam scaffold: A platform suspended from needle beams.

Open sides and ends: The edges of a platform that are more than 14 inches away from a sturdy, continuous, vertical surface (such as a building wall) or a sturdy, continuous horizontal surface (such as a floor), or a point of access. Exception: For plastering and lathing operations, the horizontal distance is 18 inches.

Outrigger: The structural member of a supported scaffold that increases the scaffold's base width, increasing support and stability.

Outrigger beam (thrustout): The structural member of a suspension scaffold or outrigger scaffold that supports the scaffold by extending the attachment point out and away from a structure.

Outrigger scaffold: A supported scaffold consisting of a platform resting on outrigger beams projecting beyond the wall or face of a structure; the inboard ends are secured inside the structure.

Overhand bricklaying: Laying bricks and masonry units so that the surface of the wall to be jointed requires the mason to lean over the wall to complete the work.

Personal fall-arrest system: An anchorage, connectors, and a body harness used to arrest a worker's fall. May also include a lanyard, deceleration device, or lifeline.

Platform: A work surface raised above lower levels. Platforms are made of individual wood planks, fabricated planks, fabricated decks, and fabricated platforms.

Pole scaffold: See "single-pole scaffold" and "double (independent) pole scaffold."

Power-operated hoist: A hoist powered by other than human energy.

Pump jack scaffold: A supported scaffold consisting of a platform supported by vertical poles and movable support brackets.

Qualified person: One who, by possession of a recognized degree, certificate, or professional standing, or who by extensive knowledge, training, and experience, has successfully demonstrated the ability to solve problems related to the subject, the work, or the project. See Page 10 for more information on the qualified person.

Rated load: The manufacturer's specified maximum load to be lifted by a hoist or to be applied to a scaffold or scaffold component.

Definitions

Repair bracket scaffold: A supported scaffold consisting of a platform supported by brackets secured around the circumference or perimeter of a chimney, stack, tank, or other supporting structure.

Roof bracket scaffold: A rooftop-supported scaffold consisting of a platform resting on angular-shaped supports.

Runner (ledger or ribbon): The lengthwise horizontal spacing or bracing member that supports the bearers.

Scaffold: Any temporary elevated platform (supported or suspended) and its supporting structure (including points of anchorage), that supports workers and materials.

Self-contained adjustable scaffold: A combination supported and suspension scaffold consisting of an adjustable platform mounted on an independent supporting frame not a part of the object worked on. Examples: rolling roof rigs, rolling outrigger systems, and some mason's adjustable supported scaffolds.

Shore scaffold: A supported scaffold placed against a structure and held in place with props.

Single-point adjustable suspension scaffold: A suspension scaffold consisting of a platform suspended by one rope from an overhead support and equipped to move the platform to desired work levels.

Single-pole scaffold: A supported scaffold consisting of a platform resting on bearers. The outside ends are supported on runners secured to a single row of posts or uprights and the inner ends are supported by a structure.

Stair tower (scaffold stairway/tower): A tower that contains internal stairways and rest platforms. Used to provide access to scaffold platforms and other elevated points such as floors and roofs.

Stall load: The load at which a power-operated hoist stalls or the power is automatically disconnected.

Step, platform, and trestle ladder scaffold: A platform resting directly on the rungs of stepladders or trestle ladders.

Stilts: A pair of poles or supports with raised footrests, used to walk above the ground or working surface.

Stonesetter's multi-point adjustable suspension scaffold: A continuous-run suspension scaffold designed and used for stonemason's work.

Supported scaffold: One or more platforms supported by outrigger beams, brackets, poles, legs, uprights, posts, frames, or similar rigid support.

Definitions

Suspension scaffold: One or more platforms suspended by ropes or other non-rigid means from an overhead structure(s).

System scaffold: A scaffold consisting of posts with fixed connection points that accept runners, bearers, and diagonals interconnected at predetermined levels.

Tank builder's scaffold: A supported scaffold consisting of a platform resting on brackets directly attached to a cylindrical tank or attached to devices that are attached to a tank.

Top-plate bracket scaffold: A scaffold supported by brackets that hook over or are attached to the top of a wall. Similar to carpenter's bracket scaffolds and form scaffolds and used in residential construction for setting trusses.

Tube and coupler scaffold: A supported or suspended scaffold consisting of a platform or platforms supported by tubing, erected with coupling devices connecting uprights, braces, bearers, and runners.

Tubular welded-frame scaffold: See "fabricated frame scaffold."

Two-point suspension scaffold (swing stage): A suspension scaffold consisting of a platform supported by hangers (stirrups) suspended by two ropes from overhead supports and equipped to raise and lower the platform to desired work levels.

Unstable objects: Objects that could become dislocated, shift, and not support the loads imposed on them. Unstable objects do not constitute a safe base support for scaffolds, platforms, or workers. Examples: barrels, boxes, loose brick, and concrete blocks.

Vertical pickup: A rope used to support the horizontal rope in catenary scaffolds.

Walkway: A portion of a scaffold platform used only for access and not as a work level.

Window jack scaffold: A platform resting on a bracket or jack that projects through a window opening.

Subdivision 3/L frequently refers to **competent persons** and **qualified persons**. The terms apply to those who have special skills and are given specific responsibilities under Subdivision 3/L rules.

Definitions

Competent person

A competent person *can identify hazardous working conditions and has authorization to take prompt corrective measures to eliminate them*. The competent person, who has primary responsibility for supervising and directing all scaffolding erection, dismantling, and altering work, must:

- know Subdivision 3/L requirements applicable to the types of scaffolds used
- be able to identify and correct hazards encountered in scaffold work
- be trained in the structural integrity of the types of scaffolds used
- have authority to promptly abate hazardous worksite conditions

A competent person's duties can be shared as long as each person is qualified to perform the duty and has authority to promptly abate hazards. Subdivision 3/L requires that only competent persons do the following:

- determine feasible safe access for persons erecting and dismantling scaffolds
- inspect scaffolds and components for hazards before each work shift and after any event that could affect the scaffolds' structural integrity
- supervise and direct all scaffold erection, dismantling, and altering work
- determine the feasibility of providing fall protection for each scaffold erection and dismantling operation
- determine whether it is safe to work on scaffolds during storms or high winds
- determine whether scaffold components made from different metals can be used together
- determine whether scaffold components made by different manufacturers can be used together
- identify the cause and significance of a deteriorated scaffold component and correct the hazard
- inspect ropes used in suspension scaffolds and identify defects
- determine if multi-point suspension scaffolds need to be secured to prevent swaying

Definitions

- inspect manila or synthetic rope used for top rails or mid rails to make sure it meets the 200-pound capacity requirements in 1926.451(g)

NOTE: Many employer groups, vendors, apprenticeship programs, and labor organizations offer training on Subdivision 3/L scaffolding requirements. However, attending one of these programs does not necessarily make one competent (or a competent person). Competency *must* be demonstrated; it's usually the result of many hours of in-class training and on-the-job experience.

Qualified person

A qualified person has a *recognized degree, certificate, or professional standing* — or by *extensive knowledge, training, and experience, has successfully demonstrated the ability to solve problems related to the subject, the work, or the project.*

Scaffolds must be designed by a qualified person but not necessarily by an engineer. Exceptions: Connections for mason's adjustable multi-point suspension scaffolds, pole scaffolds more than 60 feet high, coupler and fabricated-frame scaffolds more than 125 feet high, and outrigger scaffolds must be designed by a registered professional engineer.

Scaffold capacities

Scaffolds must be able to support their own weight and at least four times the maximum intended load applied to them. Unless otherwise noted in Subdivision 3/L, scaffold components have to meet the 4-to-1 safety factor too, but only for that portion of the maximum intended load applied to them. The maximum intended load for a component depends on the scaffold type and its configuration. Note that scaffolds and components must be able to support four times the

Where can you find the requirements in Subdivision 3/L?

See 1926.451(a) for scaffold capacity requirements. Appendix A to Subdivision 3/L offers examples that can help you comply with these requirements.

maximum intended load — not the rated load. The intended load includes workers, equipment, and supply loads. The intended load should never exceed the rated load unless the design is approved by an engineer and the manufacturer.

Direct connections

Direct connections and counterweights used to balance adjustable suspension scaffolds must resist at least four times the tipping force of the scaffold. A competent person who directs the rigging of the scaffold must calculate the potential loads.

Safety factors for the counterweights, riggings, direct connections to roofs, floors, and suspension ropes of adjustable suspension scaffolds should be based on the rated load and the stall load of the hoist, not the maximum intended load. 1926.451(a)(2)

Suspension ropes, hardware, and the maximum intended load

Suspension ropes and connecting hardware on non-adjustable suspension scaffolds must be able to support, without failure, at least six times the maximum intended load applied to them. 1926.451(a)(3)

Stall loads

The stall load of any scaffold hoist cannot exceed three times its rated load. This safety factor ensures that suspension scaffold support systems are not overloaded. 1926.451(a)(5)

Design by a qualified person

Scaffolds must be designed by a qualified person and must be constructed and loaded in accordance with that design. 1926.451(a)(6)

Working safely on Scaffolds

Working safely on scaffolds

Platform construction

All scaffold platforms, except walkways and platforms used by erectors and dismantlers, must be fully decked or planked between the front uprights and the guardrail supports. The opening between the uprights and the planking can't exceed one inch unless the employer demonstrates that a wider opening is necessary. (The maximum opening can't exceed 9½ inches.)

Where can you find the requirements in Subdivision 3/L?

See 1926.451(b) for the complete requirements on scaffold platform construction.

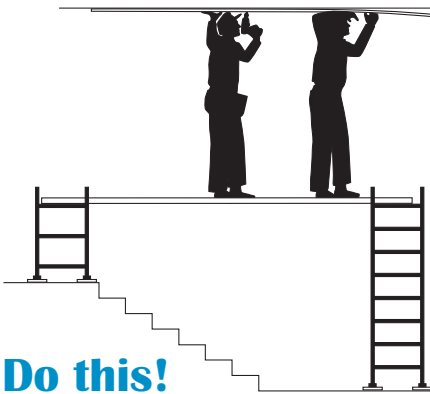

Do this!

When you're working in enclosed or tight spaces, use appropriate scaffolding frames, platforms, and connecting components. Don't improvise for the sake of convenience. To make sure your scaffold is safe, have it checked by a competent person.

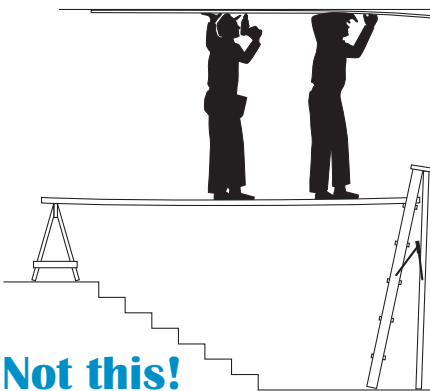

Not this!

Platform gaps

Platform units must be placed so that the spaces between the units do not exceed one inch — unless more space is necessary; for example, fitting around uprights with side brackets to extend platform width. The maximum opening cannot exceed 9½ inches. 1926.451(b)(1)(i)

Platform and walkway widths

Platforms and walkways must be at least 18 inches wide. If work areas are too narrow for 18-inch platforms or walkways, workers can use narrower platforms but they must be protected from fall hazards by guardrails and/or personal fall-arrest systems. OR-OSHA allows 12-inch widths for ladder jack, top-plate bracket, roof bracket, and pump-jack scaffolds. 1926.451(b)(2) & 1926.451(b)(2)(ii)

Front edge of platforms

The front edge of a scaffold platform cannot be more than 14 inches from the face of a structure unless guardrails or personal fall-arrest systems are used to protect workers from falling between the structure and the platform. There are two exceptions to this requirement: (1) the front edge distance for outrigger scaffolds must be no more than three inches, and (2) scaffolds used for plastering and lathing work can be no more than 18 inches from the face of a structure. 1926.451(b)(3)

Platform lengths

A platform 10 feet or less in length must extend at least 6 inches, but no more than 12 inches, beyond its support unless the excess length is guarded or can support workers and material without tipping. A platform longer than 10 feet can extend no more than 18 inches beyond a support unless the excess length is guarded or can support workers and material without tipping. 1926.451(b)(5)(i) & 1926.451(b)(5)(ii)

Working safely on scaffolds

Abutted planks

When platform planks are abutted to create a long platform, each abutted end must rest on a separate support. Abutted planks touch end to end on separate support surfaces; they do not rest on one another. 1926.451(b)(6)

Overlapped planks

Platform planks overlapped to create a long platform must overlap at least 12 inches over supports unless the planks are nailed together or otherwise restrained so they do not move. 1926.451(b)(7)

Direction changes

Any platform that rests on a bearer at an angle other than a right angle must be laid first. Platforms that rest at right angles over the same bearer must rest on top of the first platform. Make sure that all platform planks are fully bearing to eliminate potential instability. 1926.451(b)(8)

Paint (opaque) finishes

Wood platforms cannot be covered with opaque finishes, because opaque finishes cover defects in wood. Wood platform edges, however, may be marked for identification. Preservatives or slip-resistant and fire-retardant finishes are acceptable as long as the finish does not cover structural defects or make them hard to spot. 1926.451(b)(9)

Mixed or modified components

Scaffold components made by different manufacturers cannot be mixed unless they fit together easily and do not change the scaffold's integrity. Components made by different manufacturers cannot be modified to intermix unless a competent person approves. 1926.451(b)(10)

Components made from different metals

Scaffold components made from different metals cannot be used together unless a competent person approves. If a competent person determines that mixing components made from different metals could reduce their strength, the employer must take corrective action. If a competent person can't make the determination, then different metals must not be used. 1926.451(b)(11)

Working safely on scaffolds

Access to scaffolds

Employers must provide all workers with safe access to scaffolds and scaffold platforms. Workers must use ladders or stairways to reach platforms that are more than 2 feet above or below the access point. Do not use cross braces as a means of access. Note that permanent stairways or portable ladders must meet the requirements of Subdivision 3/X (stairways and ladders) of the construction safety and health standards.

Where can you find scaffold access requirements in Subdivision 3/L?

See 1926.451(e).

Bottom rung or step

The bottom step or rung of hook-on ladders, attachable ladders, and stairway-type ladders must be no more than 24 inches above or below the scaffold supporting level. 1926.451(e)(2) & (e)(3)

Rest platforms

Hook-on and attachable ladders on supported scaffolds more than 35 feet high must have rest platforms at 35-foot intervals; stairway-type ladders must have rest platforms every 12 feet. Integral prefabricated scaffold-access frames must have rest platforms every 35 feet.

Erecting and dismantling

Erectors and dismantlers must comply with the requirements of 1926.451(e)(9)(i)-(iv), summarized below:

- Means of access must be determined by a competent person. The competent person, designated by the employer, must determine if safe access is feasible at each stage of the erecting and dismantling process.
- Hook-on or attachable ladders must be installed as soon as possible after scaffold erection begins.
- End frames of tubular welded frame scaffolds that have parallel, level horizontal members may be used for access.
- Cross bracing is not an acceptable means of access.



Don't do this! — Don't climb braces to reach a scaffold platform. Use stairways or ladders to reach platforms more than two feet above or below the access point.

Protecting workers from falling objects

Workers on scaffolds must wear hardhats and be protected by toeboards, screens, guardrail systems, debris nets, catch platforms, or canopies when falling objects are a hazard. Hardhats cannot be the only means of protecting workers from falling objects. Note that workers must wear hardhats only if falling objects are a hazard. If there is no hazard from falling objects, then hardhats are not required.

Where can you find the requirements in Subdivision 3/L?

See 1926.451(h).

Persons working below

If tools, materials, or equipment could fall from a scaffold and strike persons below, the area below the scaffold must be barricaded or a toeboard must be placed along the edge of the scaffold platform. When tools, materials, or equipment are piled higher than the top edge of the toeboard, paneling or screening must protect persons below. Alternatively, guardrail systems, canopies, or catch platforms may be installed to retain materials. 1926.451(h)(2)

**Working
safely on
scaffolds**

Working safely on scaffolds

Protecting workers from falling

Workers on scaffolds more than 10 feet above a lower level must use fall protection. The employer has the option, in many cases, of protecting workers with guardrails or personal fall-arrest systems. On single-point or two-point adjustable suspension scaffolds, however, guardrails and personal fall-arrest systems are required. On other types of scaffolds only personal fall-arrest systems are allowed. Fall protection requirements for those who install suspension scaffold support systems on floors, roofs, and other elevated surfaces are included in 1926, Subdivision 3/M.

Where can you find fall protection requirements in Subdivision 3/L?
See 1926.451(g).

Remember, when you work from a scaffold more than 10 feet above a lower level, you must be protected from falling. The table below shows fall protection required by Subdivision 3/L for various types of scaffolds.



On single-point and two-point adjustable suspension scaffolds, workers must be protected with guardrails and personal fall-arrest systems.

Fall protection required	Type of scaffold
Personal fall-arrest system	<ul style="list-style-type: none"> • boatswain’s chair • catenary scaffold • float scaffold • needle beam scaffold • ladder jack scaffold
Guardrails	<ul style="list-style-type: none"> • self-contained adjustable scaffold when platform is supported by the frame structure • walkways located within a scaffold
Personal fall-arrest system and guardrails	<ul style="list-style-type: none"> • single-point adjustable suspension scaffold • two-point adjustable scaffold • self-contained adjustable scaffold when platform is supported by ropes
Personal fall-arrest system, guardrails, or grabline	<ul style="list-style-type: none"> • crawling board (chicken ladder)
Personal fall-arrest system or guardrails	<ul style="list-style-type: none"> • overhand bricklaying on a supported scaffold • all other types of types of scaffolds not identified in this table

Personal fall-arrest systems

A personal fall arrest system consists of an anchorage, connectors, and a body harness. It may also include a lanyard, deceleration device, or lifeline. Persons who work from a boatswain's chair, catenary scaffold, float scaffold, needle beam scaffold, or ladder jack scaffold must be protected by a personal fall-arrest system. 1926.451(g)(1)(i)

Personal fall-arrest systems and guardrails

Workers on single-point or two-point adjustable suspension scaffolds must be protected by personal fall-arrest systems and guardrail systems. 1926.451(g)(1)(ii)

Workers must also use personal fall-arrest systems and guardrails on self-contained adjustable scaffolds that are supported only by ropes (with no safety catch to support the platform if the rope fails). 1926.451(g)(1)(iv)

The top edge of top rails on supported scaffolds — and on all suspended scaffolds where both a guardrail and a personal fall arrest system are required — must be between 38 inches and 45 inches above the platform surface. When conditions warrant, the height of the top edge may exceed 45 inches. 1926.451(g)(4)(ii)

Cross bracing

Cross bracing is acceptable in place of a midrail when the crossing point of two braces is between 20 inches and 30 inches above the work platform. Cross bracing can be used as a toprail when the crossing point is between 38 inches and 48 inches above the work platform. The end points at each upright must be no more than 48 inches apart. Cross bracing can be substituted for either the toprail or the midrail on a scaffold system — but not both. The crossing point must be at the appropriate toprail or midrail height. 1926.451(g)(4)(xv)

Personal fall arrest systems for erectors and dismantlers

Workers who erect or dismantle supported scaffolds must, if feasible, use fall protection. A competent person, designated by the employer, must make the feasibility determination at each stage of the erecting and dismantling process. 1926.451(g)(2)

Working safely on scaffolds

Aerial lifts

The fall protection required for persons who work on aerial lifts depends on the type of aerial lift used. The table below shows acceptable fall protection.

Type of lift	Fall protection required
Vehicle-mounted elevating and rotating work platforms (ANSI A92.2 devices)	Platforms other than buckets or baskets must include guardrail systems – guardrails, a midrail, and toeboards. Each person who works on a boom-supported platform must wear a body harness/belt and lanyard attached to the boom or basket. (Body belts may be used only for fall restraint.)
Manually propelled elevating aerial platforms (ANSI A92.3 devices)	The platform must have a guardrail at least 42 inches \pm 3 inches above the floor, a midrail, and toeboards at least 4 inches high.
Boom-supported elevating work platforms (ANSI A92.5 devices)	The platform must have a guardrail at least 42 inches \pm 3 inches above the floor, a midrail, and toeboards at least 4 inches high. Each worker on the platform must wear a body harness/belt and lanyard attached to the boom or platform.
Self-propelled elevating work platforms (ANSI A92.6 devices)	The platform must have a guardrail 42 inches \pm 3 inches above the floor, a midrail, and toeboards at least 4 inches high.

Lanyards and personal fall-arrest systems

Personal fall-arrest systems used on scaffolds must be attached by a lanyard to a vertical lifeline, horizontal lifeline, or structural member that will hold at least 5,000 pounds. A competent person should decide the most appropriate connection. All personal fall-arrest systems must meet the requirements in 1926.502(d), Subdivision 3/M. When a lanyard is connected to a horizontal lifeline on a single-point or two-point adjustable suspension scaffold, the scaffold must have independent support lines and automatic locking devices that can stop the scaffold if the suspension ropes fail. 1926.451(g)(3)

Safe work practices

Damaged scaffolds and components

Any part of a damaged scaffold or component must be removed from service until it is repaired or replaced. 1926.451(f)(4)

Erecting, moving, dismantling

Scaffolds must be erected, moved, dismantled, or altered only under the supervision of a competent person. The competent person must be on the worksite to direct and supervise all scaffold erecting, dismantling, altering, and moving operations. Work must be performed only by trained, experienced persons selected by the competent person. 1926.451(f)(7)

Where can you find safe work practices requirements in Subdivision 3/L?

See 1926.451(f).

Horizontal movement

A scaffold cannot be moved horizontally when a worker is on it unless it has been designed by a registered professional engineer specifically for horizontal movement. 1926.451(f)(5)

Load capacities

Scaffolds and scaffold components must not be loaded over their maximum intended loads or rated capacities. Remember that the maximum intended load for a component depends on the scaffold type and configuration. Scaffolds and components must be able to support four times their maximum intended load — not the rated load. The intended load includes workers, equipment, and supply loads. The intended load should never exceed the rated load unless the design is approved by an engineer and the manufacturer.

Ladders and large area scaffolds

Ladders can be used only on large area scaffolds; they cannot be used on other types of platforms to increase the working height. Large area scaffolds include pole scaffolds, tube and coupler scaffolds, systems scaffolds, or fabricated frame scaffolds erected over an entire work area. 1926.451(f)(15)

Power lines

Workers must stay clear of power lines and any conductive material on the scaffold. The minimum clearance is 10 feet for all uninsulated lines and insulated lines more than 300 volts. The minimum clearance for insulated lines less than 300 volts is three feet. 1926.451(f)(6)

Scaffold inspection

Scaffolds and components must be inspected by a competent person before each workday and after any incident that could weaken them. 1926.451(f)(3)

Working safely on scaffolds

Working safely on scaffolds

Shore or lean-to scaffolds

Shore or lean-to scaffolds are prohibited. They are not properly designed and are a potential safety hazard for anyone who works on them. 1926.451(f)(2)

Slippery scaffolds

Working on a scaffold coated with snow, ice, or other slippery material is prohibited unless it is necessary to remove the slippery material. 1926.451(f)(8)

Storms and high winds

Working on a scaffold is prohibited during storms or high winds unless a competent person has determined that it is safe to be on the scaffold and workers are protected by personal fall-arrest systems or wind screens. 1926.451(f)(12)

Suspension ropes

Suspension ropes must be protected from heat and acids or other corrosive substances or be made from material that will not be damaged by corrosive substances. 1926.451(f)(11)

Tag lines

When a scaffold might be struck by a swinging load, tag lines or equivalent means must be used to control the load. 1926.451(f)(9)

Safe practice checklist

Access

- ✓ Maintain a safe access to scaffolds and scaffold platforms.
- ✓ Don't climb cross braces to reach a scaffold platform.
- ✓ Use ladders or stairways to reach platforms that are more than 2 feet above or below the access point.

Components and connections

- ✓ Never use damaged scaffold components. Repair or replace them immediately. Make sure a competent person inspects the components before each workshift.
- ✓ Do not modify components.
- ✓ Don't mix components made by different manufacturers.
- ✓ Never use damaged wire rope.

Environment

- ✓ Watch for electrical hazards, slippery platforms, and strong winds.

Erecting, dismantling, and moving

- ✓ Have only trained and experienced workers erect suspension scaffolds.
- ✓ Never roll a scaffold by yourself while you are on it.
- ✓ Never use wood outrigger systems.

Fall protection and falling objects

- ✓ Match fall-protection systems with the appropriate type of scaffold.
- ✓ Make sure platforms are guarded to keep workers and equipment from falling.
- ✓ Don't drop anything from a scaffold.

Inspection

- ✓ Inspect components, connections, planks, and structures regularly for hazards.

Ladders

- ✓ Don't use ladders for any reason on a standard scaffold platform.

Leveling

- ✓ Keep the scaffold level, plumb, and square.
- ✓ Don't use bricks, blocks, barrels or other unstable objects to level a scaffold.

Platforms

- ✓ Don't work on slippery platforms.
- ✓ Never use a stage that is too long or too short for the job.
- ✓ Planking must be sound and meet OR-OSHA requirements.
- ✓ Don't use makeshift methods to increase the working height of a scaffold platform.

Working safely on scaffolds



Notes

Supported scaffolds

OR-OSHA defines a supported scaffold as *one or more platforms supported by outrigger beams, brackets, poles, legs, uprights, posts, frames, or similar rigid support.*

Where can you find the requirements in Subdivision 3/L?

1926.451(c) has the general requirements for supported scaffolds. Subdivision 3/L, 1926.452 has specific requirements that apply to supported scaffolds. Don't forget that the other 1926.451 general requirements for platform capacity, platform construction, access, use, fall protection, and falling-object protection can also apply.

Beginning on the next page, you'll find illustrations and highlights of Subdivision 3/L requirements that apply to specific types of supported scaffolds.

Height to smallest base dimension

Supported scaffolds with a height-to-smallest base-width ratio of more than 4-to-1 (including outrigger supports) must be restrained from tipping by ties, guys, braces, or equivalent means. "Equivalent means" refers to other designs, materials, or methods that provide an equal or greater degree of safety for workers. 1926.451(c)(1)

Guys, ties, and braces

Guys, ties, and braces must be installed where horizontal members support both inner and outer legs. They must be installed according to the manufacturer's recommendations or at the closest horizontal member to the 4-to-1 height and repeated vertically at least every 20 feet if the scaffold is up to 3 feet wide; every 26 feet if the scaffold is greater than 3 feet wide. 1926.451(c)(1)(i) & (ii)

Be sure to use vertical and horizontal tie-ins to keep the scaffold from falling into or away from a structure. A qualified person must design the tie-ins.

Support surface

Poles, legs, posts, frames, and uprights must bear on base plates and mud sills or a firm foundation. The scaffold structure must be plumb and braced so that it does not sway. Footings must offer full support without settling. Base plates are always required on supported scaffolds; however, a concrete slab is considered a firm foundation and can be substituted for mudsills. 1926.451(c)(2) & (3)

Forklifts and front-end loaders

Do not use a front-end loader to support a scaffold platform unless the vehicle has been designed by the manufacturer specifically for that purpose. 1926.451(c)(2)(iv)

Types of scaffolds and lifts

Supported scaffolds

Note: These illustrations are useful only for identifying various types of scaffolds used in the construction industry. They are not intended as compliance guidelines, nor are they intended to reflect Subdivision 3/L requirements.

Bricklayer's square scaffold

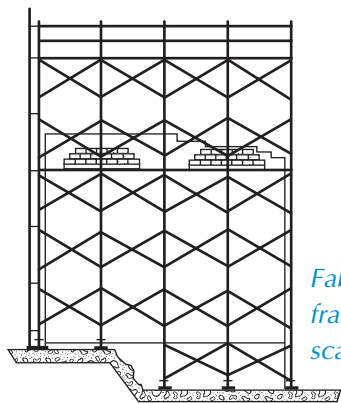
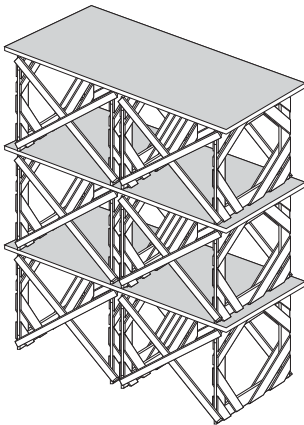

Fabricated frame scaffold

Carpenter's bracket scaffold

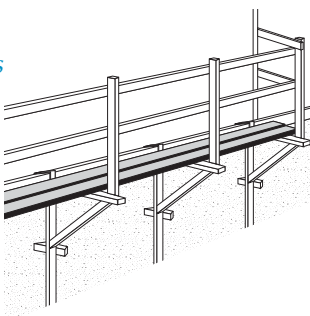

You can use a forklift to support a platform only if the entire platform is attached to the forks and the vehicle is not moved when someone is on the platform. *Attached* means the platform is fastened to the forks with bolts or by an equally safe method. All scaffold capacity, construction, access, use, and fall-protection requirements apply. 1926.451(c)(2)(v)

Types of supported scaffolds

Bricklayer's square scaffolds

- Wood bricklayer's scaffolds must be reinforced with gussets on both sides of each corner.
- Install diagonal braces on all sides of each square.
- Install diagonal braces between squares on the rear and front sides of the scaffold.
- Do not exceed three tiers in height. One square must rest directly above the other.

Crawling boards (chicken ladders)

- Crawling boards must extend from the roof peak to the eaves when used for roof construction, repair, or maintenance.
- Crawling boards must be secured to the roof by ridge hooks or other means that meet equivalent strength and durability criteria.

Fabricated frame scaffolds

- When you move platforms to the next level, leave the existing platform undisturbed until the new end frames have been set in place and braced.
- Frames and panels must be braced by cross, horizontal, or diagonal braces that secure vertical members together laterally.
- Join frames and panels together vertically by coupling or stacking pins.
- If uplift could displace scaffold end frames or panels, the frames or panels must be locked together vertically.
- Scaffolds more than 125 feet above their base plates must be designed by a registered professional engineer.

Form scaffolds and carpenter's bracket scaffolds

- Brackets, except those for wooden bracket-form scaffolds, must be attached to the supporting formwork or structure by nails; a metal-stud attachment device; welding; hooking over a secured structural supporting member; or, for carpenter's bracket scaffolds, by a bolt extending through the scaffold frame and the structure wall.
- Wooden bracket-form scaffolds must be an integral part of the form panel.
- Folding metal brackets, when extended, must be either bolted or secured with a locking-type pin.

Horse scaffolds

- Scaffolds must not be constructed more than two tiers or 10 feet high, whichever is less.
- When you arrange horses in tiers, place each horse directly over the horse in the tier below. The legs of each horse must be nailed down or otherwise secured to prevent displacement. Each tier must be cross braced.

Ladder jack scaffolds

- Platforms must not exceed 20 feet in height.
- All ladders used to support ladder jack scaffolds must meet the requirements of Subdivision 3/X, Stairways and Ladders.
- Job-made ladders cannot be used to support ladder jack scaffolds.
- The ladder jack must be designed and constructed to bear on the side rails and ladder rungs or on the ladder rungs alone.
- Ladders that support ladder jacks must be placed, fastened, or equipped with devices to prevent slipping.
- Scaffold platforms must not be bridged one to another.

Mobile scaffolds

- Use cross, horizontal, or diagonal braces to prevent scaffolds from collapsing and to secure vertical members.
- Scaffolds must be plumb, level, and squared.
- All brace connections must be secured.
- Lock casters and wheels to prevent scaffold movement.
- When you use manual force to move a scaffold, apply the force as close to the base as practicable, but not more than 5 feet above the supporting surface.
- Do not use forklifts, trucks, similar motor vehicles, or add-on motors to propel a scaffold unless the scaffold is specifically designed to be used with them.
- Stabilize scaffolds so they do not tip when they are moved.
- Platforms cannot extend outward beyond the scaffold base supports without outrigger frames or equivalent devices.
- Use screw jacks or equivalent means to level the scaffold.
- Caster stems and wheel stems must be secured in scaffold legs.
- Before moving a scaffold, make sure each worker on the scaffold is aware of the move.

Supported scaffolds

Horse scaffold

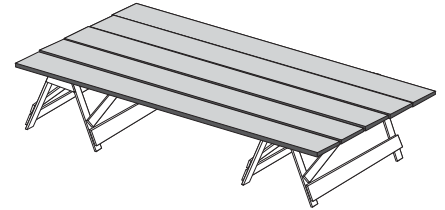

Ladder jack scaffold

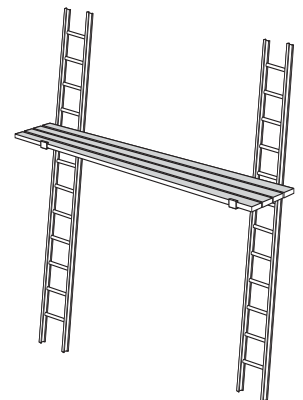

Mobile scaffold

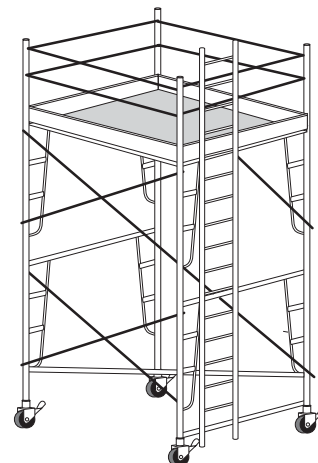

Supported scaffolds

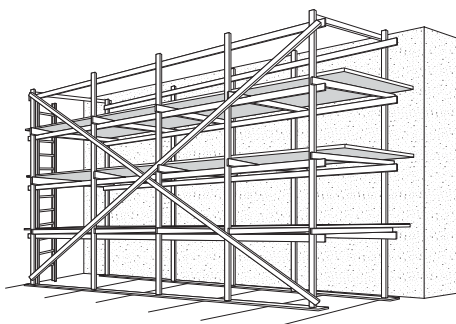
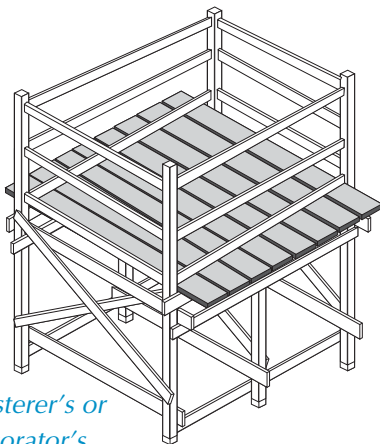
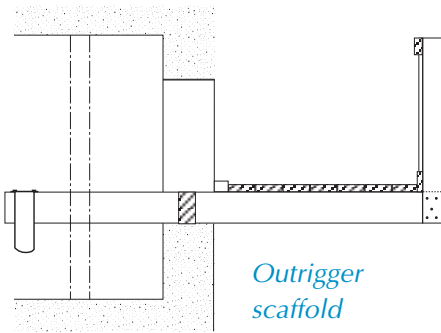

Outrigger scaffolds

- The inboard end of outrigger beams, measured from the fulcrum point to the extreme point of anchorage, must be not less than 1.5 times the length of the outboard.
- Outrigger beams fabricated in the shape of an I-beam or channel must be placed so that the web section is vertical.
- The fulcrum point of outrigger beams must rest on secure bearings extending at least 6 inches in each horizontal dimension.
- Outrigger beams must be secured in place and braced at the fulcrum point against tipping.
- Securely anchor the inboard ends of outrigger beams. Use braced struts bearing against sills that contact the overhead beams or ceiling, or use tension members secured to the floor joists underfoot.
- The entire supporting structure must be securely braced to prevent horizontal movement.
- Platform units must be secured to outriggers.
- Scaffolds and scaffold components must be designed by a registered professional engineer.

Plasterer's, decorator's, and large-area scaffolds

- These scaffolds must be constructed in accordance with the requirements for pole scaffolds, tube-and-coupler scaffolds, or fabricated frame scaffolds.

Pole scaffolds

- When you move platforms to the next level, leave the existing platform undisturbed until new bearers are set and braced.
- Install cross bracing between the inner and outer sets of poles on double pole scaffolds.
- Install diagonal bracing in both directions across the entire inside face of double-pole scaffolds that support loads of 50 pounds or more per square foot.
- Install diagonal bracing in both directions across the entire outside face of double- and single-pole scaffolds.
- Install runners and bearers on edge.
- Extend bearers a minimum of 3 inches beyond the outside edges of runners.
- Extend runners over a minimum of two poles. Support by bearing blocks securely attached to the poles.
- Do not splice braces, bearers, and runners between poles.
- Where you splice wooden poles, square the ends. Make sure that wood splice plates are on at least two adjacent sides and that they extend at least 2 feet on either side of the splice.
- Pole scaffolds more than 60 feet in height must be designed by a registered professional engineer.

Supported scaffolds

Pump jack scaffolds

- Pump jack brackets, braces, and accessories must be fabricated from metal plates and angles. Each pump jack bracket must have two positive gripping mechanisms.
- Secure poles to the structure with rigid triangular bracing.
- Workbenches must not be used as scaffold platforms.
- Wood poles must be straight-grained and free of shakes; large, loose (or dead) knots, and other defects.
- Wood poles constructed in two continuous lengths must be joined together with the seam parallel to the bracket.
- If two-by-fours are spliced to make a pole, mending plates must be installed at all splices to maintain the full strength of the member.

Roof bracket scaffolds

- Scaffold brackets must fit the pitch of the roof and provide a level support for the platform.
- Anchor brackets with nails or secure with first-grade manila rope at least $\frac{3}{4}$ -inch diameter.

Step, platform, and trestle ladder scaffolds

- Scaffold platforms must not be any higher than the second-highest rung or step of the ladder supporting the platform.
- All ladders used in conjunction with step, platform, and trestle ladder scaffolds must meet the pertinent requirements of Subdivision 3/X, Stairways and Ladders. Do not use job-made ladders.
- Ladders that support step, platform, and trestle ladder scaffolds must be placed, fastened, or equipped with devices to prevent slipping.
- Scaffolds must not be bridged one to another.

Stilts

- A worker may wear stilts only on a large-area scaffold.
- When a worker is using stilts on a large-area scaffold protected by guardrails, the guardrails must be increased in height by an amount equal to the height of the stilts.
- Stilts can be used only on surfaces that are flat and free of pits, holes, and other obstructions.
- Keep stilts properly maintained. Any alteration of the original equipment must be approved by the manufacturer.

Tube and coupler scaffolds

- When you move platforms to the next level, leave the existing platform undisturbed until new bearers are set and braced.
- Install transverse bracing forming an “X” across the width of the scaffold, at every third set of posts horizontally, and every fourth runner vertically.

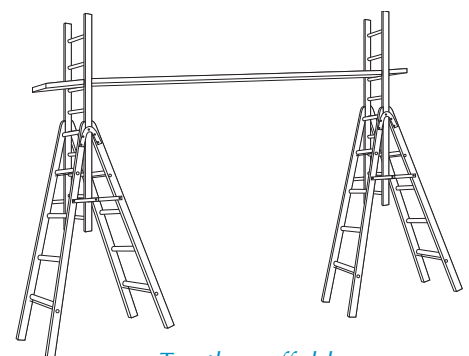
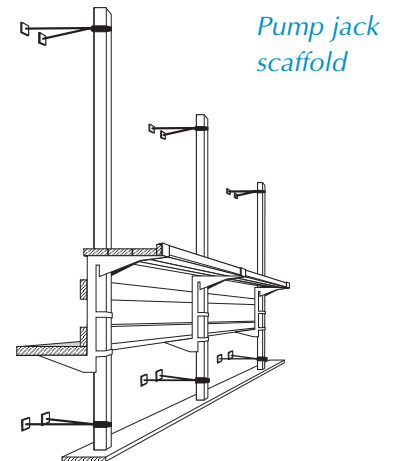

Supported scaffolds

Tube and coupler scaffold

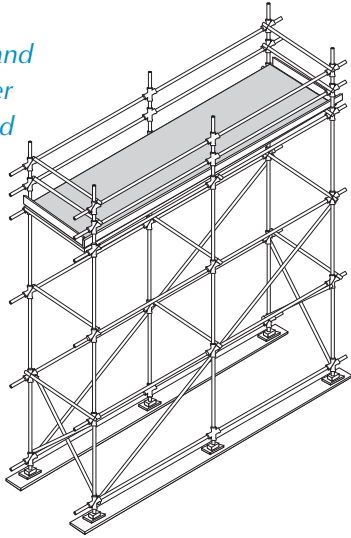

- On straight-run scaffolds, make sure longitudinal bracing across the inner and outer rows of posts is installed diagonally in both directions. The bracing must extend from the base of the end posts upward to the top of the scaffold at approximately a 45-degree angle.
- When you cannot attach bracing to posts, attach it to the runners as close to the post as possible.
- Install bearers transversely between posts.
- Extend bearers beyond the posts and runners. They must have full contact with the coupler.
- Install runners along the length of the scaffold on both the inside and outside posts at level heights.
- Interlock runners on straight runs in continuous lengths and couple them to each post. The bottom runners and bearers must be located as close to the base as possible.
- Couplers must be made from a structural metal such as drop-forged steel, malleable iron, or structural-grade aluminum.
- Tube and coupler scaffolds more than 125 feet in height must be designed by a registered professional engineer.

Window jack scaffolds

- Scaffolds must be securely attached to the window opening.
- Use the scaffold to work only at the window opening through which the jack is placed.
- Do not use window jacks to support planks placed between one window jack and another.

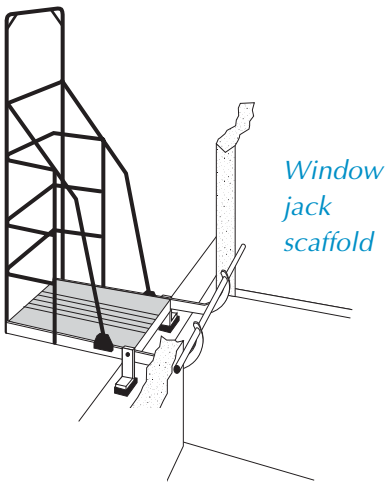

Suspension scaffolds

OR-OSHA defines a suspension scaffold as one or more platforms suspended by ropes or other non-rigid means from an overhead structure. Beginning on Page 31 you will find illustrations and highlights of Subdivision 3/L requirements that apply to the most common types of suspension scaffolds.

Where can you find the requirements in Subdivision 3/L?

1926.451(d) has the general requirements for suspension scaffolds. 1926.452 has specific requirements that apply to specific types of suspension scaffolds. Don't forget that the other 1926.451 general requirements for platform capacity, platform construction, access, use, fall protections, and falling object protection can also apply.

Suspension scaffolds

Support device load requirements

Support devices such as outrigger beams, cornice hooks, and parapet clamps must rest on surfaces that can support at least four times the scaffold's load when the scaffold operates at the rated load of the hoist (or at least 1.5 times the scaffold load at the stall capacity of the hoist, whichever is greater). 1926.451(d)(1)

Outrigger beams

Outrigger beams must be made of structural metal or material of equivalent strength and must be restrained. The outrigger beams must be secured directly to the supporting surface or stabilized by counterweights. Because masons' multi-point adjustable suspension scaffolds bear heavy loads, their supporting outrigger beams can't be stabilized by counterweights; the supporting surface could become dangerously overloaded. 1926.451 (d)(2) & (3)

Outrigger beams must have stop bolts or shackles at both ends and be securely fastened with the flanges turned out when channel iron beams are used in place of I-beams. Bearing supports must be perpendicular to the beam center line. Outrigger beams must be set and maintained with the web vertically. The shackle that attaches the rope to the outrigger beam must be placed directly over the center line of the stirrup. 1926.451(d)(4)

Direct connections

A competent person must evaluate all direct connections and confirm that scaffold-supporting surfaces can support the imposed loads. An engineer must design masons' multi-point adjustable suspension scaffold connections. 1926.451(d)(3)(i)

Suspension scaffolds

Counterweights

Counterweights must be used only for their intended purpose and must not be changed or moved until the scaffold is dismantled. Sand and other flowable material cannot be used as a counterweight. Solid materials such as large concrete or lead blocks designed to be used as counterweight are acceptable, however. 1926.451(d)(3)(ii)

Hoists and related equipment

Winding drum hoists must have at least four wraps of the suspension rope at the lowest point of scaffold travel. When other types of hoists are used, the suspension ropes must be long enough so the scaffold can be lowered without the rope end passing through the hoist. 1926.451(d)(6)

Gasoline-powered equipment and hoists cannot be used on suspension scaffolds. 1926.451(d)(14)

Suspension scaffold hoists must have an operating brake and an automatic braking device or locking pawl that engages when a hoist makes a sudden change in momentum or an accelerated overspeed. 1926.451(d)(16)

Manually operated hoists must descend with a positive crank force. 1926.451(d)(17)

Suspension wire rope

Repaired wire rope cannot be used for suspension rope. 1926.451(d)(7)

The load end of wire suspension ropes must be fitted with properly sized thimbles and secured by eye splicing or equivalent means. 1926.451(d)(9)

A competent person must check wire ropes for defects before each workshift. Damaged rope must be replaced. 1926.451(d)(10)

Swaged attachments or spliced eyes on wire suspension ropes cannot be used unless they are made by a rope manufacturer or a qualified person. 1926.451(d)(11)

Securing scaffolds

Two-point and multi-point suspension scaffolds must be secured if they could sway; a competent person must make the determination. Window cleaners' anchors cannot be used to secure suspension scaffolds. 1926.451(d)(18)

Safety devices

Emergency escape and rescue devices cannot be used as working platforms. This requirement does not apply to systems that function as suspension scaffolds and as emergency/rescue devices. 1926.451(d)(19)

Tiebacks

Tiebacks must be at least as strong as suspension ropes and must be secured to a structurally sound anchorage on the building or

structure. Do not use standpipes, vents, other piping systems, or electrical conduit for anchorages.

Be sure to install tiebacks perpendicular to the face of the building or structure or use opposing angle tiebacks. Do not install single tiebacks at an angle to the face of a building or structure. Support devices such as cornice hooks, roof hooks, or parapet clamps must also be secured by properly installed tiebacks.

Types of suspension scaffolds

Catenary scaffolds

- No more than one platform can be placed between consecutive vertical pickups and no more than two platforms must be used on a catenary scaffold.
- Platforms supported by wire ropes must have hook-shaped stops on each end to prevent them from slipping off the wire ropes. These hooks must be placed so that they will prevent the platform from falling if one of the horizontal wire ropes breaks.
- Wire ropes must not be tightened so much that a scaffold load will overstress them.
- Wire ropes must be continuous, without splices between anchors.

Float scaffolds

- The platform must be supported by at least two bearers, each of which must project 6 or more inches beyond the platform on both sides. Each bearer must be securely fastened to the platform.
- Rope connections must keep the platform from shifting or slipping.

Interior hung scaffolds

- Scaffolds must be suspended only from a roof or other structural members such as ceiling beams.
- Inspect overhead supporting members such as roofs or ceiling beams before erecting the scaffold.
- Connect suspension ropes and cables to overhead supporting members by shackles, clips, or thimbles.

Multi-level suspended scaffolds

- Scaffolds must be equipped with additional independent support lines equal to the number of supported points, as strong as the suspension ropes, and rigged to support the scaffold if the suspension rope(s) fail.
- Independent support lines and suspension ropes must not be attached to the same anchorage points.
- Supports for platforms must be attached directly to the support stirrup and not to any other platform.

Suspension scaffolds

Note: *these illustrations are useful only for identifying various types of scaffolds used in the construction industry. They are not intended as compliance guidelines, nor are they intended to reflect Subdivision 3/L requirements.*

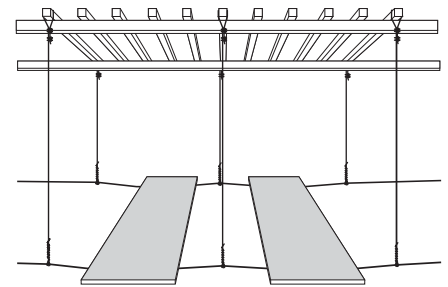

Catenary scaffold

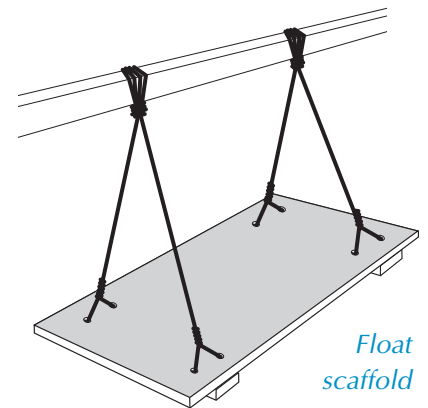

Float scaffold

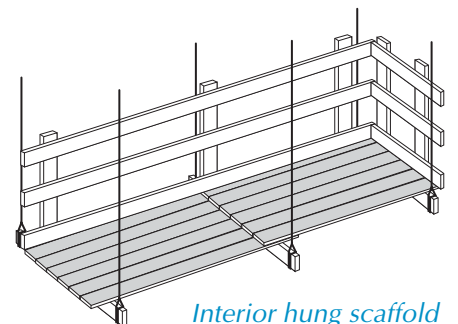

Interior hung scaffold

Suspension scaffolds

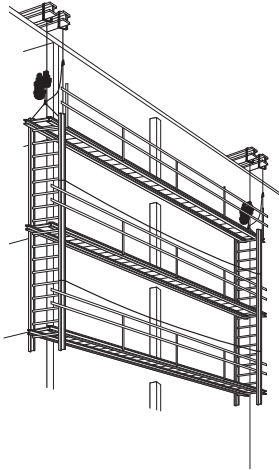

Multi-level suspended scaffold

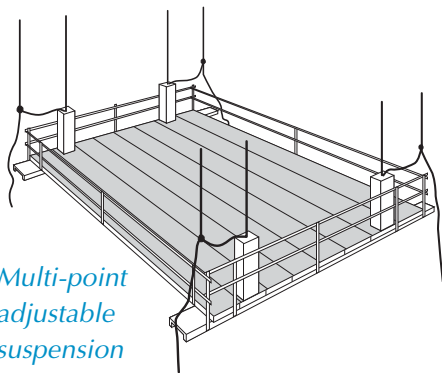

Multi-point adjustable suspension scaffold

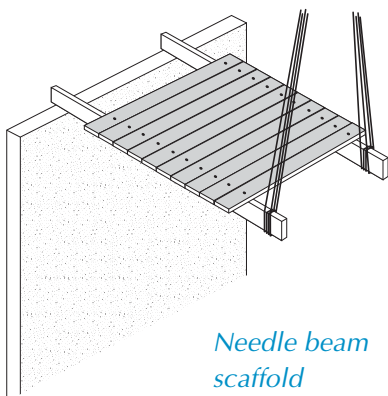

Needle beam scaffold

Multi-point adjustable suspension scaffolds

- When you use two or more scaffolds, they must not be bridged to one another unless they are designed to be bridged, the bridge connections are articulated, and the hoists are properly sized.
- If bridges are not used, you can go from one platform to another only when the platforms are the same height and are abutting.
- Scaffolds must be suspended from metal outriggers, brackets, wire rope slings, or hooks.

Needle beam scaffolds

- Scaffold support beams must be installed on edge.
- Use ropes or hangers for supports. One end of a needle beam scaffold, however, may be supported by a permanent structural member.
- Ropes must be securely attached to the needle beams.
- The support connection must prevent the needle beam from rolling or becoming displaced.
- Platform units must be securely attached to the needle beams. Cleats and overhang are not acceptable.

Repair bracket scaffolds

- Brackets must be secured by one or more wire ropes at least $\frac{1}{2}$ inch in diameter.
- Attach each bracket to the securing wire rope (or ropes) by a locking device that will keep the bracket and the rope from separating.
- Each bracket, at the contact point between the supporting structure and the bottom of the bracket, must have a shoe (heel block or foot) that will prevent the bracket from moving laterally.
- Platforms must be secured to the brackets so they do not move or separate from the brackets.
- If you place a wire rope around a structure to anchor a personal fall-arrest system for workers erecting or dismantling a scaffold, the wire rope must meet Subdivision 3/M requirements and must be of at least $\frac{5}{16}$ -inch diameter.
- Each wire rope used to secure brackets in place or as a personal fall-arrest system anchorage must be protected from damage.
- Use a turnbuckle at least 1 inch in diameter to tension wire ropes that secure brackets in place or that anchor personal fall-arrest systems.
- Each turnbuckle must be connected to the other end of its rope by an appropriately sized eyesplice thimble.

Suspension scaffolds

- Do not use U-bolt wire rope clips on any wire rope to secure brackets or to anchor personal fall arrest systems.
- Do not drop materials over the outside of the supporting structure.
- Erect scaffolds only one direction around a structure.

Single-point adjustable suspension scaffolds

- If two single-point adjustable suspension scaffolds are combined to form a two-point adjustable suspension scaffold, the scaffold must comply with the requirements for two-point adjustable suspension scaffolds.
- Under most circumstances, the supporting rope between the scaffold and the suspension device must be kept vertical.
- Boatswain's chair tackle must consist of correctly sized ball bearings or bushed blocks containing safety hooks and properly "eye-spliced" minimum $\frac{5}{8}$ -inch diameter first-grade manila rope.
- Boatswain's chair seat slings must be reeved through four corner holes in the seat, must cross each other on the underside of the seat, and must be rigged to prevent slippage which could cause an out-of-level condition.
- Boatswain's chair seat slings must be a minimum of $\frac{5}{8}$ -inch diameter rope that will satisfy the strength, slip resistance, and durability of first-grade manila rope.
- When workers use a heat-producing process such as gas or arc welding, boatswain's chair seat slings must be a minimum of $\frac{3}{8}$ -inch wire rope.
- Non-cross-laminated wood boatswain's chairs must be reinforced on their undersides by cleats securely fastened to prevent the boards from splitting.

Single-point adjustable suspension scaffold

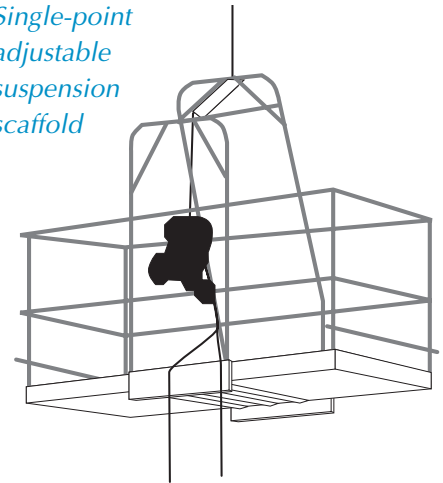

Two-point adjustable suspension scaffolds

- Platforms must not be more than 36 inches wide unless they are designed by a qualified person.
- Platforms must be securely fastened to hangers.
- The blocks for fiber or synthetic ropes must consist of at least one double and one single block. The sheaves of all blocks must fit the size of the rope used.
- Platforms must be ladder-type, plank-type, beam-type, or light-metal-type.
- Do not bridge or connect two-point scaffolds to one another when raising or lowering them unless the bridge connections are attached and the hoists are properly sized.
- You can go from one platform to another only when the platforms are at the same height, are abutting, and you use walk-through stirrups specifically designed for this purpose.

Two-point adjustable suspension scaffold

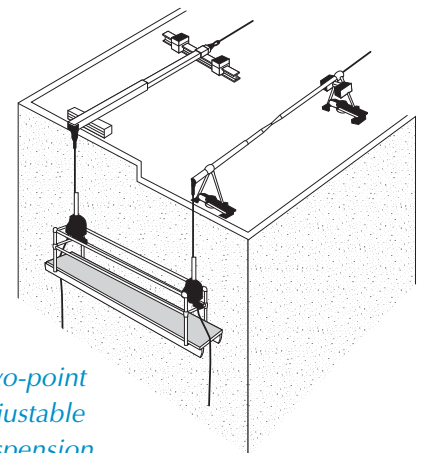

Aerial lifts

Aerial lifts

An aerial lift is an extensible or articulating device designed to position workers and handle materials. Aerial lifts can be powered or manually operated and do not necessarily have to rotate about a vertical axis. Subdivision 3/L covers only vehicle-mounted elevation and rotating aerial lifts (ANSI A92.2 device). However, Oregon OSHA has added additional rules to Subdivision 3/L covering three other types of aerial lifts:

- manually propelled elevating aerial platforms (ANSI A92.3 device)
- boom-supported elevating work platforms (ANSI A92.5 device)
- self-propelled elevating work platforms and scissor lifts (ANSI A92.6 device)

These additional rules require workers to have the manufacturer's operation manual with the lifts when they use them and to follow all operating and maintenance instructions.

Where can you find aerial lift requirements in Subdivision 3/L?

See 1926.453. Note that 1926.451 and 1926.452 do not apply to aerial lifts.

Field modifications

Aerial lifts may be "field modified" provided the manufacturer certifies in writing that modifications conform to all applicable provisions of ANSI A92.2 and the requirements of 1926.453. 1926.453(a)(2)

Ladder and tower trucks

Aerial ladders must be secured in the lower traveling position before they can be transported on highways. 1926.453(b)(1)

Extensible and articulating boom platforms

Lift controls must be tested before platforms are used. Workers must stand firmly on the floor of the basket and must wear a body belt and a lanyard attached to the boom or basket. 1926.453(b)(2)

Body belts are acceptable in this case, as part of a tether system. However, body belts are not acceptable as part of a personal fall-arrest system.

Electrical tests

All electrical tests must conform to ANSI A92.2-1969 section 5. 1926.453(b)(3)

Bursting safety factor

ANSI A92.2-1969, section 4.9, applies to all critical hydraulic and pneumatic components. Critical components are those in which a failure would result in a free fall or free rotation of the boom.

Welding standards

Welding work must conform to the following standards:

- Standard Qualification Procedure, AWS B3.0-41
- Recommended Practices for Automotive Welding Design, AWS D8.4-61
- Standard Qualification of Welding Procedures and Welders for Piping and Tubing, AWS D10.9-69
- Specifications for Welding Highway and Railway Bridges, AWS D2.0-69

Each person who works from a scaffold must be trained to recognize hazards associated with that scaffold and to control or minimize the hazards. Training must cover:

- electrical hazards, such as overhead power transmission lines
- fall hazards and methods to control the hazards
- falling object hazards and methods to protect persons from falling objects
- how to use the scaffold's walkways, platform components, and access areas
- the scaffold's load capacity and the types of loads appropriate for the scaffold
- the requirements of Subdivision 3/L that apply to the scaffold

Where can you find the requirements in Subdivision 3/L?

See 1926.454.

Workers who erect or dismantle scaffolds

Workers who erect, disassemble, move, or maintain a scaffold must be trained by a competent person. Training must cover:

- scaffold hazards
- erecting, disassembling, moving, and maintenance procedures
- design criteria, maximum intended load-carrying capacity, and use

Retraining

When an employer has reason to believe a worker lacks the skill or knowledge to safely use, erect, or dismantle a scaffold, the employer must retrain the worker. Other reasons for retraining include worksite changes that create new hazards and changes in the types of scaffolds, fall protection, or falling object protection used. 1926.454(c)

The table on the following page summarizes the training requirements for persons who work from scaffolds and persons who erect or dismantle scaffolds.

Training requirements

Summary of training requirements for scaffold users

	Those who work from scaffolds	Those who erect and dismantle scaffolds
Critical scaffold issues	<ul style="list-style-type: none"> • Falling objects • Fall protection • Material handling on scaffolds • Scaffold load capacities 	<ul style="list-style-type: none"> • Scaffold design criteria • Scaffold erecting, disassembling, moving, and maintenance procedures • Scaffold erecting, disassembling and, moving hazards • Scaffold load capacities
What they need to know	<ul style="list-style-type: none"> • How to use appropriate fall-protection systems • How to control scaffold hazards • How to use scaffold walkways, platform components, and access areas • Maximum-intended and load-carrying capacities of scaffolds • Subdivision 3/L requirements 	<ul style="list-style-type: none"> • Hazards involved in erecting/ dismantling • Erection/ dismantling planning procedures • How to deal with electrical hazards • How to inspect components • Appropriate design criteria • Maximum-intended and load-carrying capacities of scaffolds • Division 3/L requirements
Who can train them	<p>Any person who has training and experience in the critical scaffold issues (above) and who can teach the issues to scaffold users</p> <p>Subdivision 3/L refers to a person with these skills as a <i>qualified person</i>. See Page 10 in this guide for more information on the qualified person</p>	<p>Any person who has training and experience in the critical scaffold issues (above), who can teach the issues to erectors/dismantlers, <i>and</i> who has authority to control scaffold hazards</p> <p>Subdivision 3/L refers to a person with these skills as a <i>competent person</i>. See Page 9 in this guide for more information on the competent person</p>
How often to train them	<ul style="list-style-type: none"> • Before they begin a new job • Whenever changes at the worksite present new hazards • Whenever they fail to demonstrate skills related to any of the critical scaffold issues 	<ul style="list-style-type: none"> • Before they begin a new job • Whenever changes at the worksite present new hazards • Whenever they fail to demonstrate skills related to any of the critical scaffold issues

Effective training programs don't just happen. They require careful planning, explicit goals and objectives, dedicated instructors, and motivated students. It doesn't matter whether the activity is athletics, academics, or occupational safety and health. The underlying training concepts are similar: (1) design a training program, (2) conduct training, (3) evaluate training effectiveness, and (4) improve training through feedback.

1. Design a training program

Determine whether a worksite problem can be solved by training.

Will training solve the problem or are hazards or engineering problems causing injuries? Training is most effective when it focuses on what workers need to know to do their jobs safely. Training is especially helpful for inexperienced workers, new workers, and workers unfamiliar with special processes and equipment.

Identify training needs.

Establish what the worker is expected to do and identify hazardous tasks. Analyze each task to determine what the worker must learn to do a job safely.

Design learning activities.

Learning activities enable workers to demonstrate that they've acquired desired skills and knowledge. The activities should simulate actual job tasks as closely as possible. Learning activities can be group-oriented, with lectures, role playing, and demonstrations. Or they can be designed as self-paced activities for individual workers. Ultimately, the design depends on the employer's creativity and training resources.

2. Conduct the training

Plan the training structure and format. Consider the number, frequency, and length of sessions. Determine instructional techniques and who will do the training. Make sure the training is well-organized and has clearly defined objectives. Give workers an overview of what they'll learn. Relate training materials to tasks and jobs. Include hands-on experience and role-playing activities, if possible. Reinforce learning by summarizing objectives and key concepts. Be sure to let workers participate in discussions and ask questions.

3. Evaluate training effectiveness

How do you know training is accomplishing your objectives? Develop a plan to objectively evaluate training effectiveness. Ask workers what they've learned through training. Ask supervisors if workers are accomplishing training goals. Examine trends in your injury or illness statistics for changes that training may have influenced.

Training guidelines

4. Improve training through feedback

Collect and evaluate feedback from workers, supervisors, and others affected by the training. When you're sifting through what people had to say about the training, consider these questions:

- Did the training focus on critical elements of the job?
- Were major gaps in workers' knowledge or skills covered?
- Were the training objectives presented clearly?
- Did the objectives state the performance levels expected of workers?
- Did learning activities simulate actual work tasks?
- Were learning activities appropriate for the knowledge and skills the jobs required?
- Were training materials organized and presented clearly?
- Were workers motivated to learn?
- Were workers encouraged to participate and to ask questions?

Adjust the training program if the feedback warrants a change.

Employers must establish procedures to ensure that a worker who falls from a scaffold receives immediate attention. Emergency procedures should be fully documented before workers begin work or use fall-arrest or restraint systems. Emergency procedures should identify key rescue and medical personnel, equipment available for rescue, communications procedures, retrieval methods, and first-aid requirements. The following lists identify safe practice guidelines for developing emergency response planning procedures, responding to emergencies, and investigating accidents.



Planning guidelines

Before on-site work begins

- Make the fire department or emergency responders aware of the job specifications at the site and any factors that may slow response time.
- Create one or more joint training sessions between key on-site personnel and emergency responders.
- Document the rescue plan and make sure it is posted at the worksite.
- Mark the job site with signs and note the easiest access routes into and out of the site.

As on-site work progresses

- Identify on-site equipment that can be used for rescue and retrieval. Examples: boomlifts, ladders, and forklifts.
- Maintain a current equipment inventory at the site. Equipment may change frequently as the job progresses.
- Reevaluate and update the emergency-response plan if on-site work tasks change.

Emergency-response actions

- Call 9-1-1 or other emergency numbers indicated on the emergency response plan. Use 9-1-1 for ambulance service but remember that most 9-1-1 responders are not trained to rescue an injured worker suspended in a personal fall-arrest system. Rescue procedures must ensure prompt response to a suspended worker. The 9-1-1 number does not ensure prompt response. First responders should clear a path to the victim. Others should be sent to direct emergency personnel to the scene.
- Make sure only qualified personnel attempt a technical rescue.
- Prohibit all non-essential personnel from the rescue area.

Handling emergencies

Handling emergencies

- Talk to the victim; determine the victim's condition, if possible.
- If the victim is accessible: Comfort and check vital signs. If necessary: Administer CPR, and attempt to stop bleeding.
- Do not attempt a solo rescue if the victim is suspended. Wait for trained emergency responders.

Accident investigation guidelines

- Report fatalities and catastrophes to Oregon OSHA within eight hours.
- Report injuries requiring overnight hospitalization to Oregon OSHA within 24 hours.
- Identify all equipment associated with the accident and put it out of service until the accident investigation is complete.
- Document what went wrong, step by step.
- Review the fall-protection plan; determine how the plan could be changed to prevent similar accidents; revise the plan accordingly.
- Have a qualified person examine equipment associated with the accident; if damaged, repair or replace it. If it contributed to the accident, determine how and why, then replace it.
- Do not disturb the scene of a fatality or catastrophe.