

# GUARDING OF PAPER BALING PRESSES

## **NOTE**

The technical information in this book was current at the time of printing in 1984. While the guarding principles are still valid, the information does not necessarily reflect technological changes since the booklet was first published.

This booklet should be read in conjunction with the OSH *Guidelines for Guarding Principles and General Safety for Machinery*.

First published by the Department of Labour,  
Wellington, New Zealand, in 1984

This pdf created November 2001

[www.osh.dol.govt.nz](http://www.osh.dol.govt.nz)

---

# CONTENTS

---

|  |    |
|--|----|
| INTRODUCTION                           | 4  |
| MACHINE CONFIGURATIONS                 | 4  |
| Vertical Presses                       | 4  |
| Horizontal Presses                     | 4  |
| REQUIREMENTS OF THE MACHINERY ACT 1950 | 5  |
| HAZARDS AND GUARDING METHODS           | 5  |
| Vertical Presses                       | 5  |
| Horizontal Presses                     | 8  |
| GENERAL REQUIREMENTS                   | 10 |
| Controls                               | 10 |
| Design and Construction                | 10 |
| GUARD TYPES AND REQUIREMENTS           | 11 |
| Fixed Guards                           | 11 |
| Interlocked Guards                     | 11 |
| Presence-Sensing Devices               | 13 |
| CASE STUDIES                           | 13 |
| Portable Vertical Baling Press         | 13 |
| High-Production Horizontal Press       | 14 |
| FURTHER INFORMATION                    | 15 |

---

# INTRODUCTION

---

Paper baling presses are used in many supermarkets, shopping centres and recycling centres to reduce large quantities of waste paper and cardboard into compact, easily handled bales.

Although generally simple, these machines can inflict severe injuries unless they are guarded and operated correctly.

This booklet briefly describes the hazards and how they can be eliminated.

---

## MACHINE CONFIGURATIONS

---

### Vertical Presses

In general these are portable machines, used intermittently rather than in continuous large-scale recycling operations.

They consist of a vertical “box” with two openings: an upper door or chute into which the paper is inserted, and a lower door from which the compacted bale is removed.

The upper opening may be fitted with a door, or there may be a chute or hopper into which the paper is loaded. The lower opening is usually fitted with a strong door to resist the forces generated during compression of the paper.

Larger non-portable vertical paper baling presses, which are fed from an upper or mezzanine floor, are very similar in feature to floor-to-floor wool presses. Information given in the Department of Labour’s booklet *Guarding of Floor-to-Floor Wool Presses* also applies to these machines.

### Horizontal Presses

These range from small portable machines to large, fixed, high-production machines. Some are fitted with a hopper above the compression chamber. Others are loaded directly through a door or lid at the top.

The compacted bales are either removed through a door at the base or by swinging the whole bale chamber open. Some larger machines force the paper through a constriction at the end of the compression chamber, where baling straps are wrapped around it. The compressed paper is “extruded” continuously until the required bale size is reached.

Some smaller machines compact paper and general refuse into standard paper or plastic rubbish bags inside a cylindrical or rectangular chamber. This type of machine is generally loaded through a vertical hopper opening into the compression chamber.

---

## **REQUIREMENTS OF THE MACHINERY ACT 1950**

---

The Machinery Act 1950 requires every moving part of any prime mover, every part of any transmission machinery and every dangerous part of any machine to be securely fenced. This requirement applies unless the parts are in such a position or of such construction as to be as safe to every person employed or working on the premises as they would be if securely fenced.

Paper baling presses must therefore fulfil these requirements:

- (a) Any exposed moving part of the machine's motor must be covered unless it is impossible for the operator to reach it.
- (b) Shafts, belts, pulleys and all other transmission components must be fully enclosed unless they are beyond the operator's reach.
- (c) All dangerous parts must be made safe by design, or be guarded to prevent access while they are in motion.

---

## **HAZARDS AND GUARDING METHODS**

---

### **Vertical Presses**

The principal hazards of vertical presses are caused by the moving platen at various points:

- (a) On some machines, the platen rises above the sides of the top chamber, causing a shearing point at the beginning of its downward stroke. This shearing point must be eliminated by raising the sides of the chamber or by limiting the upper position of the platen.
- (b) There should be no openings in the chamber walls through which the moving platen is accessible at any point of its stroke, with the exception of slots for baling bands (discussed under (d)).

- (c) At the bottom of its compression stroke, the platen in most cases extends below the bottom of the upper door. At the beginning of the return stroke, a shearing point is created between the rising platen and the lower edge of the upper door or chamber side. This should be prevented by ensuring that the platen cannot be raised unless the lower door is closed, or by fitting a "false front" to the upper edge of the platen to increase its effective depth so that its upper edge does not extend below the lower edge of the upper door (see fig. 1).

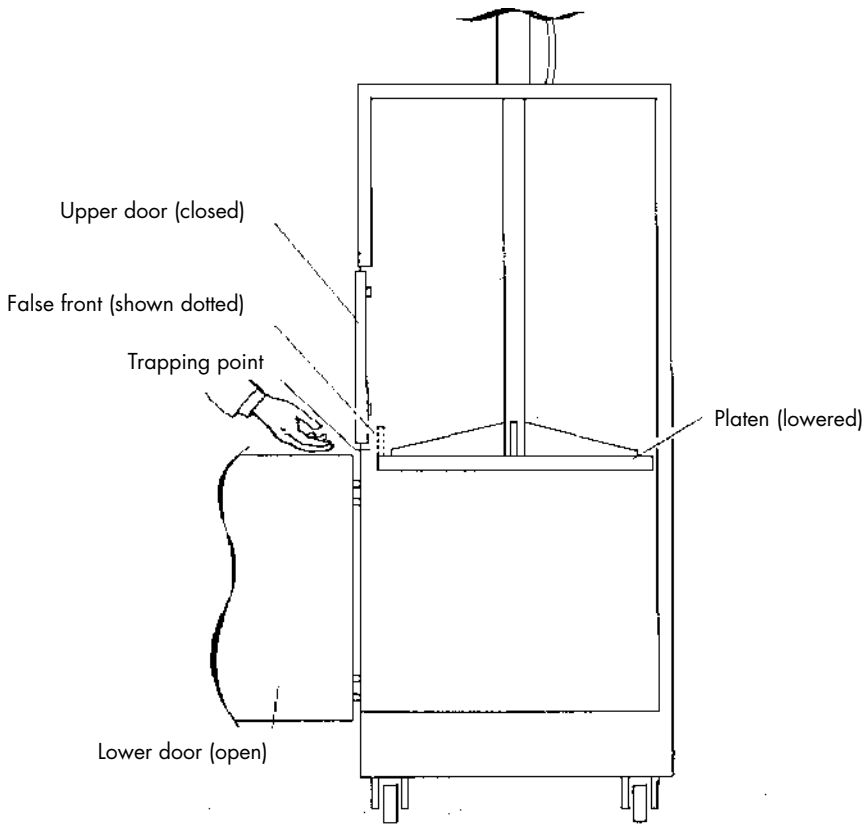

Fig. 1: False front on platen; preventing shearing edge.

- (d) On machines where the bale is contained by straps or bands, there are slots in the sides of the lower chamber to allow the straps to be inserted when the bale is complete. The upper ends of these slots may be above the platen when it is fully lowered, with the same dangers mentioned in (c). Thickening the platen in the area of these slots can prevent this hazard. An alternative is to fit projecting “flanges” on either side of these slots to prevent the operator reaching through to them (see fig. 2).

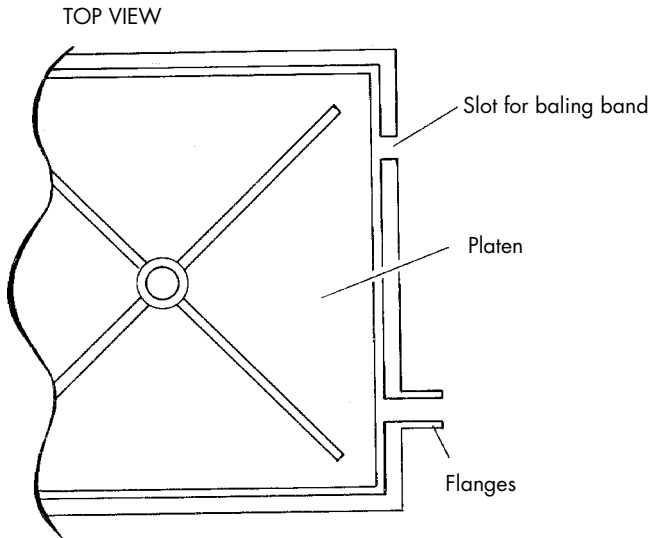

Fig. 2: Flanges prevent access to moving platen.

- (e) Where the paper is manually fed through an opening which allows access to the moving platen (as is usually the case), this opening must be covered by a door or guard which is interlocked to prevent the platen moving until the door is fully closed.
- (f) Some presses have horizontally hinged flaps, opening downward, in front of the feed openings. These flaps are restrained at an angle when open to form a sloping chute for feeding material into the press. These flaps are held closed by a latch which is automatically released by the platen as it returns to its upper position at the end of a pressing cycle. This can result in the flap dropping unexpectedly and striking a worker. Flaps of this type should be held closed by a manually operated latch as well as, or instead of, the automatic one.

## Horizontal Presses

In general, the hazards are similar to those of vertical machines, although accessibility may be different because of the different configuration.

Some horizontal presses are large, high-production machines fed through a top door. In other machines the top and back pivot at floor level as a unit, forming a large loading chamber which closes and precompresses the paper before the platen makes a stroke (see fig. 3).

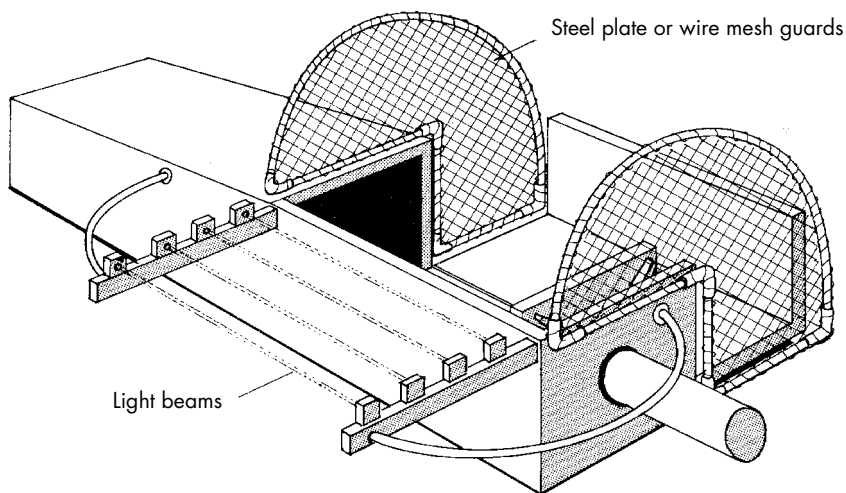
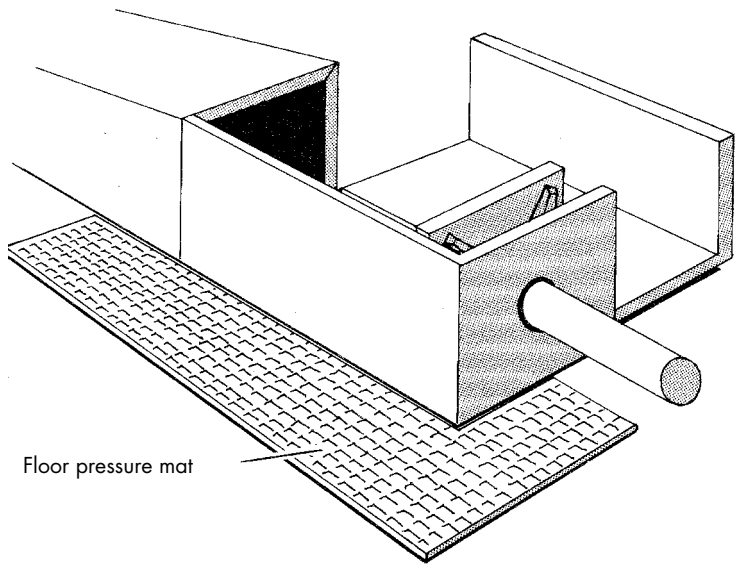

Fig. 3: Horizontal press fitted with photoelectric cell and mesh sideguards.

In either case, the moving portion is usually too heavy to move manually, so is opened and closed by hydraulic cylinders or other mechanical means. The moving parts create trapping points as they close, and sometimes as they open, depending on the machine's configuration.

Plates should be fitted at the sides to guard the shearing points. Operator access to the front of the machine during the dangerous movement should also be prevented. This may be achieved by fitting a presence-sensing device (e.g. light beams or a pressure-sensitive floor mat), an interlocked distance bar with appropriate side guards, an interlocked sliding gate or any other effective means (see figs. 3, 4, and 5).

Smaller portable horizontal machines, which compact refuse into bags or simply compress it into a chamber, are generally fed through a hopper on top of the machine.



Floor pressure mat

Fig. 4: Interlocked pressure-sensitive floor mat.

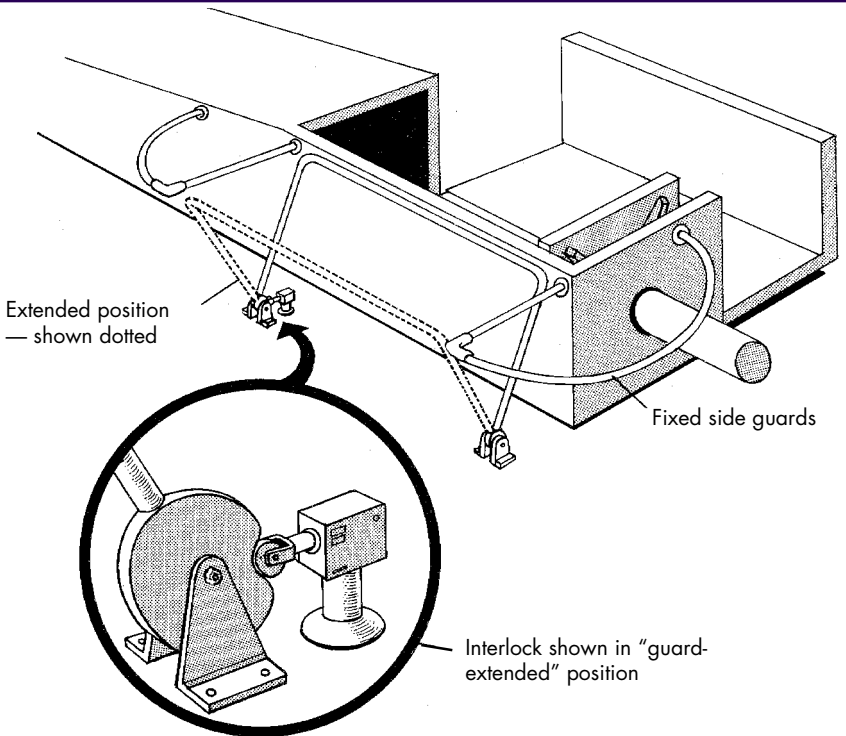

Extended position  
— shown dotted

Fixed side guards

Interlock shown in "guard-extended" position

Fig. 5: Interlocked distance guard.

The principal hazard is the trapping points caused as the platen moves across the bottom of the hopper, especially as it passes the hopper edge. If the platen is thin, there will be a further trapping point created as the platen returns after its compression stroke. Most machines have an extended top to the platen, which closes off the bottom of the hopper when the ram moves across, to prevent refuse dropping down behind it during the compression stroke. This eliminates the hazard.

Access to trapping points can be prevented by increasing the height of the hopper sides so that the operator cannot reach them. Alternatively, an interlocked lid can be fitted to the hopper to prevent the dangerous movement until it is fully closed.

---

## **GENERAL REQUIREMENTS**

---

### **Controls**

All power controls must provide effective control of the machine, be constructed and placed so as to prevent inadvertent starting, and be placed in a convenient position for the person using the machine.

A means of isolating the machine from its power supply or of locking out the controls must be fitted if a person cleaning, adjusting or maintaining the machine cannot be seen from the operator's position.

It is important for controls to be arranged so that activation of a control indicates the direction in which the machine part will move. For example, a control lever on a vertical press should be moved downwards to lower the platen and vice versa.

Any control for stopping the machine should be easily operated and clearly identified, for example a red "mushroom" type button.

### **Design and Construction**

All of the machine's structural elements, i.e. main frame, panels, hinges, latches, pins, fastenings, and so on must be designed and constructed so as to adequately and safely withstand the maximum loads imposed upon them.

---

# GUARD TYPES AND REQUIREMENTS

---

## Fixed Guards

In general, where a dangerous part is to be guarded, and access is not required during normal operation, a fixed guard should be fitted.

Fixed guards should completely prevent access to the dangerous parts. They should be rugged enough to withstand likely abuse, and be secured firmly to the machine by fastenings requiring a tool to remove them. Parallel bars, wire mesh or impact-resistant clear plastic panels may be used if visibility is required.

## Interlocked Guards

Where access is required to insert or remove workplaces during operation of a machine, and where fixed guards are impractical, an interlocked guard is commonly fitted. These guards consist of sliding or hinged panels which, when closed, prevent access to the dangerous part. An interlock is fitted to prevent the machine making any dangerous movement until the guard is fully shut.

The interlock may take the form of a mechanical linkage which prevents the controls from moving from the "safe" position until the guard is fully closed, (see figs 6 and 7), an electrical limit switch, or a hydraulic (or pneumatic) valve acting on the control circuit.



Fig. 6: Mechanical interlock (guard open)

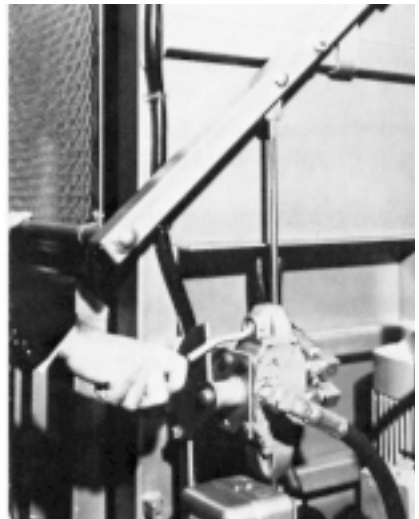

Fig. 7: Mechanical interlock (guard closed)

An interlock should be designed to ensure that:

- until the guard is fully closed, the dangerous motion cannot take place; and
- either: the guard is locked shut until the dangerous motion has ceased (including any overrun);
- or: opening the guard immediately stops the dangerous motion.

Electrical limit switches used for guard interlocking should be arranged so that the actuator is released when the guard is fully closed, allowing the machine to start. Opening the guard should force the actuator into the switch to separate the switch contacts and stop the machine. To achieve this, a switch with “normally closed” contacts is necessary. A “positive break” type is strongly recommended.

A cam is necessary to actuate a switch of this type. Examples are shown in fig. 8.

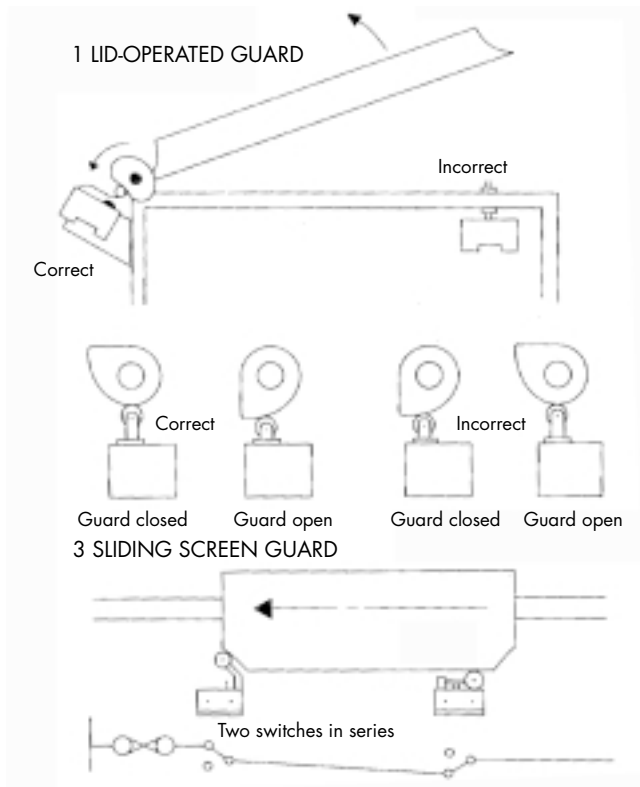

Fig. 8: Three typical interlocking systems.

The reasons for the preferred method of actuation, and further details, are set out in the Department's booklet *Electrical Interlocking of Machinery Guards*.

Where pneumatic or hydraulic valves are used for interlocking, they should be arranged and actuated in the same way as electric limit switches. This is to prevent operators bypassing the interlock and to safeguard against a sticking or jammed valve spindle, or a broken return spring.

### **Presence-Sensing Devices**

Where presence-sensing devices such as light beams or pressure-sensitive floor mats are used for machine guarding, they must be designed and installed so that they will fail to safety in any foreseeable circumstance. A monitoring circuit or self-checking device may be required to ensure that any faults are detected.

The Department of Labour should be contacted for specific advice if the use of a presence-sensing device is being considered.

---

## **CASE STUDIES**

---

To illustrate the successful application of these principles, two machines will be briefly examined.

### **Portable Vertical Baling Press: Manufactured by Richmond Industries Ltd.**

This is the MK II version of the press, and complies with the standards set out in this booklet. It is illustrated in figs 9 and 10.

When the lower door is closed, the paper or cardboard is loaded into the upper hinged door. When the chamber is full, the upper door is shut and the platen is forced down to compress the paper, then raised again. The cycle is repeated until the bale has reached the required density. The platen is then held down while the baling bands or straps are fitted. Finally, the bottom door is opened, the platen raised and the bale removed.

The platen does not rise above the sides of the enclosure, so no trapping hazard is created at this point.

The effective depth of the platen is increased at the front, and adjacent to the baling slots at the rear, to prevent the hazards created as a thin platen rises from its lowest position.



Fig. 9: Richmond Industries Mark II press — doors open.



Fig. 10: Richmond Industries Mark II press — doors closed.

The upper hinged door, through which the paper is fed, is interlocked by a covered, normally closed, positive break limit switch. This switch is actuated through a rod which is in turn actuated by a notched circular cam on the door hinge. This ensures that no dangerous motion of the platen can occur until the door is fully closed.

### **High-Production Horizontal Press: Manufactured by Hawera Engineering Ltd.**

This machine is designed for larger recycling operations, as it is of very substantial construction and is not portable.

The large loading chamber is formed by a fixed front and floor, with the top and back pivoting on hinges to allow paper to be loaded.

The two sections are closed by hydraulic cylinders, which precompress the paper into the compaction chamber. The platen then compacts the paper and forces it through a constricted outlet, where it is strapped.

The trapping points at the rear and top of the machine can be safeguarded either by preventing access to these areas (which is practical if the machine is loaded from the front only), or by fitting plates at the side of the loading area which prevent the formation of shearing points. This is detailed in fig. 3.

The trapping point at the front of the press must also be guarded. This is best achieved by preventing operator access to the area during the closing of the chamber. Light beams have been fitted across the front of the machine so that the closing motion cannot start unless the light beams are unbroken. Breaking any of the light beams immediately stops the closing motion (see fig. 3).

Other methods such as interlocked distance bars, pressure mats on the floor etc. could also be used (see figs 4 and 5).

The platen in its "open" position does not extend past the end of the compaction chamber, so no trapping point exists at the beginning of the compression stroke.

---

## **FURTHER INFORMATION**

---

You can get further safety and health information, including information on guarding machinery, from your nearest OSH office or from [www.osh.dol.govt.nz](http://www.osh.dol.govt.nz)