

FALL PROTECTION FOR ROOFING WORK

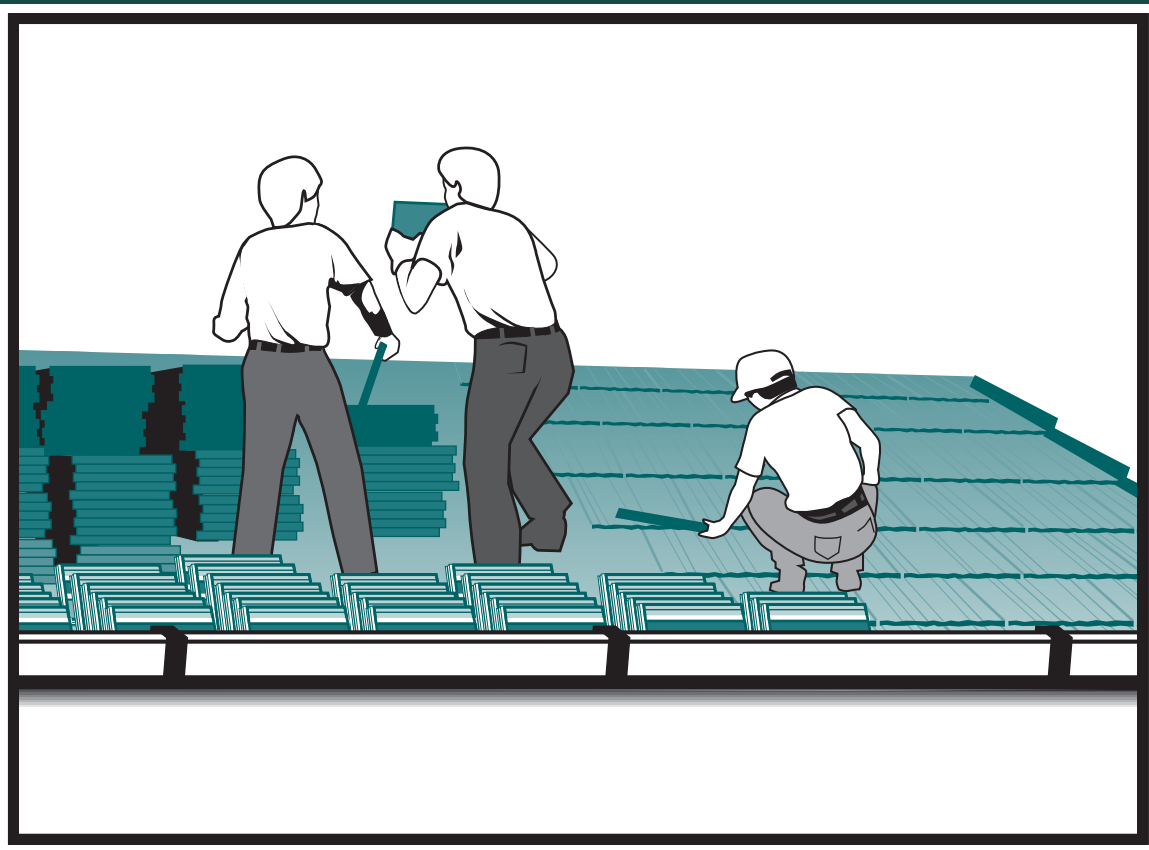

*Oregon Occupational Safety
& Health Division (OR-OSHA)*



DEPARTMENT OF
CONSUMER
& BUSINESS
SERVICES



In compliance with the *Americans With Disabilities Act (ADA)*, this publication is available in alternative formats. Call the OR-OSHA public relations manager, (503) 378-3272 (V/TTY).

Materials contained in this publication are in the public domain and may be copied and distributed without permission from Oregon OSHA.

Contents

Introduction	2
What is roofing work?	2
I. Fall-protection requirements for roofing work	3
Fall-protection requirements for the construction industry	3
Fall-protection requirements for residential-type construction	3
When Division 3, Subdivision M requirements don't apply	4
II. Thinking ahead: the importance of planning and preparation	5
III. Low-slope roofs and steep roofs	6
IV. Fall-protection systems and methods	7
Conventional fall protection	7
Other fall-protection systems	13
Summary: fall-protection options for roofers	17
V. Working safely with ladders	18
Training requirements	19
Safe practice guidelines for working with ladders	19
VI. Using a fall-protection plan	21
VII. Fall-protection training	25
Retraining	25
Certification	25
VIII. Preparing for emergencies	26
Before on-site work begins	26
As on-site work progresses	26
If an emergency occurs	27
Investigating an accident	27
Appendix: Fall-protection checklists and training certification form	28
Fall-hazard checklist	28
Fall-protection systems checklist	29
Written certification record	30
Definitions of selected terms	31
OR-OSHA services	36

Introduction

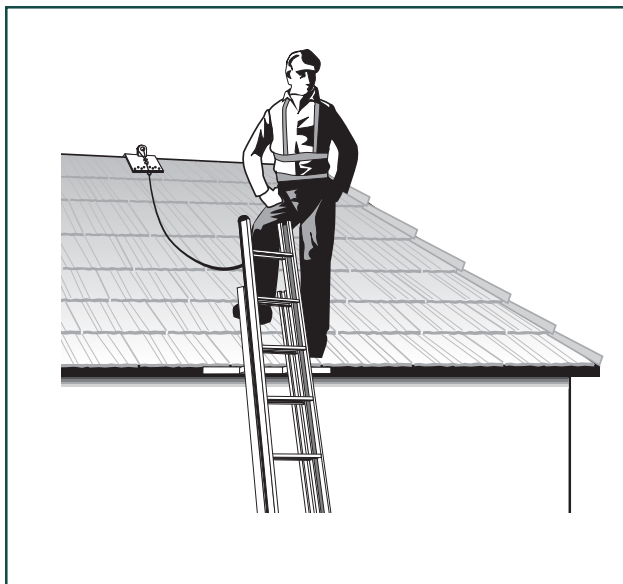

Fall protection is a broad concept. It includes training, procedures, rules, systems, and methods intended to protect workers from fall hazards. Fall protection doesn't mean bulky or cumbersome equipment, it doesn't interfere with work tasks, and it doesn't get in the way of co-workers — if you understand the concept and apply it appropriately.

Fall protection also implies shared responsibilities. If you're an employer, you must be aware of fall hazards and you must eliminate them or control your employees' exposure to them. If you're an employee, you must follow your employer's policies, procedures, and training requirements. Building owners and managers, architects, engineers, and equipment manufacturers also have responsible roles to play during a typical construction project.

This guide will help you understand the fall-protection concept and apply it to roofing work. Key terms are identified in the margins, and many words in *italic* type are defined at the back of the publication, beginning on page 31.

What is roofing work?

Roofing work refers to hoisting, storing, applying, and removing roofing materials and equipment on a roof deck. Roofing work also includes related insulation, sheet metal, and vapor barrier work, but does not include the construction of the roof deck.

I. Fall-protection requirements for roofing work

Fall-protection requirements for the construction industry

OR-OSHA's fall-protection requirements for the construction industry are in OAR 437, Division 3, Subdivision M, of the Oregon construction safety and health code. The requirements apply to virtually all *walking and working surfaces* in construction workplaces.

*Division 3,
Subdivision M*

Division 3, Subdivision M specifies:

- Where fall protection is required
- Appropriate fall-protection systems and methods
- Proper fall-protection construction and installation practices
- Supervision requirements for workers who use fall protection
- Safe work procedures for workers who use fall-protection systems
- Training requirements for workers who use fall-protection systems

Fall-protection requirements for residential-type construction

Residential-type construction applies to construction where the working environment, materials, methods, and procedures are essentially the same as those used in building a typical single-family home or townhouse. Residential construction is characterized by materials: Framing with wood or metal studs; wooden or metal floor joists and roof structures.

Workers doing residential-type construction must follow Division 3, Subdivision M requirements. However, OR-OSHA permits those doing residential-type construction to work up to 10 feet above a lower level without fall protection for tasks such as leading-edge and top-plate work, setting walls and trusses, or roofing and sheathing. Above 10 feet, workers must use guardrails, safety nets, or personal fall-arrest systems for protection.

Workers who do roofing and sheathing on residential-type structures can also use *2" x 6" roof brackets and slide guards* for fall protection under the following conditions:

- Roofs sloped 3:12 through 6:12 must have a ground-to-eave height not exceeding 25 feet.
- Roofs sloped more than 6:12 through 8:12 must have a ground-to-eave height not exceeding 25 feet. The roof brackets and slide guards must be used in multiples, spaced no more than every eight feet vertically. *All roof brackets and slide guards must bear on solid surfaces.*

The roof bracket and slide guard along the lower edge of the roof slope must be at least six inches from the roof edge, be perpendicular to the roof surface, and bear on a solid surface.

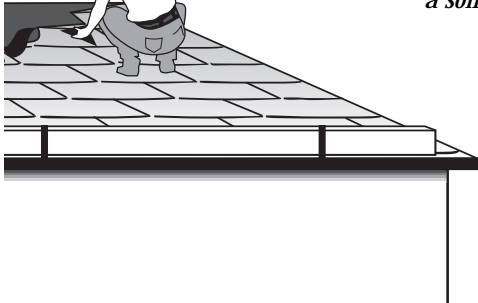

- The roof bracket and slide guard along the lower edge of the slope must be at least six inches from the roof edge and perpendicular to the roof surface. Other brackets and slide guards above the lower edge may be installed at a 60-degree angle to the roof surface. *All roof brackets and slide guards must bear on solid surfaces.*

Frequently asked question

I'm doing roofing work on a two-story house that has two roof levels. The edge of the upper roof is less than 10 feet above the lower roof. And the lower roof edge is less than 10 feet above the ground. However, the total distance from the upper roof edge to the ground is almost 20 feet. Do I need to use fall protection?

Because you would not fall more than ten feet to a lower level, you don't need to use fall protection. (Subdivision M requires fall protection for residential-type construction work when the fall distance is 10 feet or more to a lower level.) However, you should install roof brackets on the lower roof to reduce your risk of an uncontrolled slide.

When Division 3, Subdivision M requirements don't apply

If you must assess worksite conditions above a lower level before construction work begins or after the work is finished, you aren't required to use fall protection. This is because site inspection activities usually expose you to a fall hazard for just a short time. On the other hand, the person who installs fall protection may be exposed to a fall hazard for a much longer time. In this case, installing protection — and risking a fall — is greater than the risk of falling during a brief site inspection.

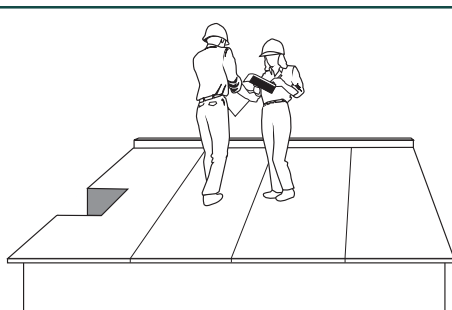

Workers don't need to use fall protection when they briefly inspect, investigate, or assess workplace conditions before a construction job begins or after the job is finished.

II. Thinking ahead: the importance of planning and preparation

Before you begin a roofing project, think about the methods, systems, and procedures that will control workers' exposure to fall hazards. Careful planning and preparation lay the groundwork for an accident-free workplace. If you are an employer, you are responsible for anticipating fall hazards at your worksite and for including fall-protection measures in your project plans. The nature and scope of the planning effort depend on the complexity of the project. Larger projects involving multiple contractors and hundreds of workers obviously require more extensive planning than reroofing a single-family home.

Communication and coordination — with customers, contractors, and suppliers — are critical elements of the planning process. If you are a contractor bidding on roofing work, you should include fall-protection equipment as a bid item. This lets your customers know how you will comply with Subdivision M requirements. However, your customers must give you enough information so you can develop bids that include appropriate fall-protection systems.

At a minimum, the planning process should identify fall hazards and the systems and methods that will control the hazards. Effective planning reduces risks for workers during a project and for others after the project is finished. For example, anchor points used by construction workers on a building project might also be used to protect window cleaners or other maintenance personnel. The following guidelines will help you with the planning process.

- Identify fall hazards workers are likely to encounter during the project.
- Identify tasks that expose workers to fall hazards.
- Describe how workers will reach the worksite (by ladders, or stairs, for example).
- Describe how workers will keep tools and materials from dropping to lower levels.
- Establish procedures for inspecting, maintaining, and storing fall-protection equipment.
- Make sure workers use appropriate fall-protection systems.
- Identify anchor point locations.
- Describe the methods for setting anchors and securing lifelines.
- Identify areas where workers may be exposed to falling objects and how they will be protected.
- Describe emergency-response procedures for workers who fall.
- Post emergency-responders' phone numbers and make sure workers know them.
- Describe equipment that will be available for rescuing workers who fall.

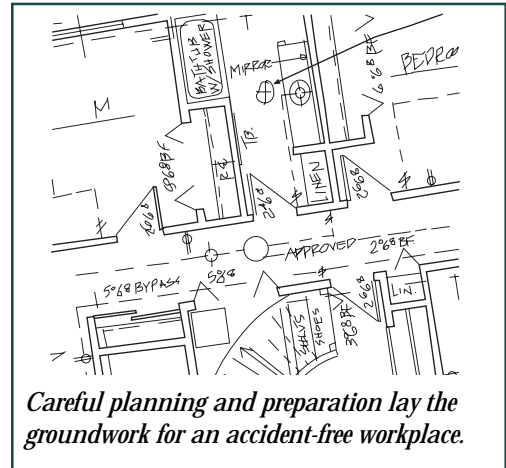

Careful planning and preparation lay the groundwork for an accident-free workplace.

III. Low-slope roofs and steep roofs

Division 3, Subdivision M, 1926.500(b) defines a roof — and that means any roof — as the exterior surface on the top of a building. However, concrete form work or a floor that temporarily becomes the top surface of a building under construction is not a roof. Subdivision M, classifies roofs into two types: low-slope and steep.

Low-slope roofs — Roofs with slopes less than or equal to 4:12
(vertical to horizontal)

If you do roofing work on a low-slope roof with unprotected sides and edges and you are six feet or more above a lower level, you must use one of the following fall-protection systems:

- Guardrail system
- Safety-net system
- Personal fall-arrest system
- Warning-line system and guardrail system
- Warning-line system and safety-net system
- Warning-line system and personal fall-arrest system
- Warning-line system and safety-monitoring system
- Safety-monitoring system (if the roof is no wider than 50 feet)
- Roof brackets and slide guards (residential-type structures only)

If you are working on the roof of a residential-type structure, you can work up to 10 feet above a lower level before you need fall protection.

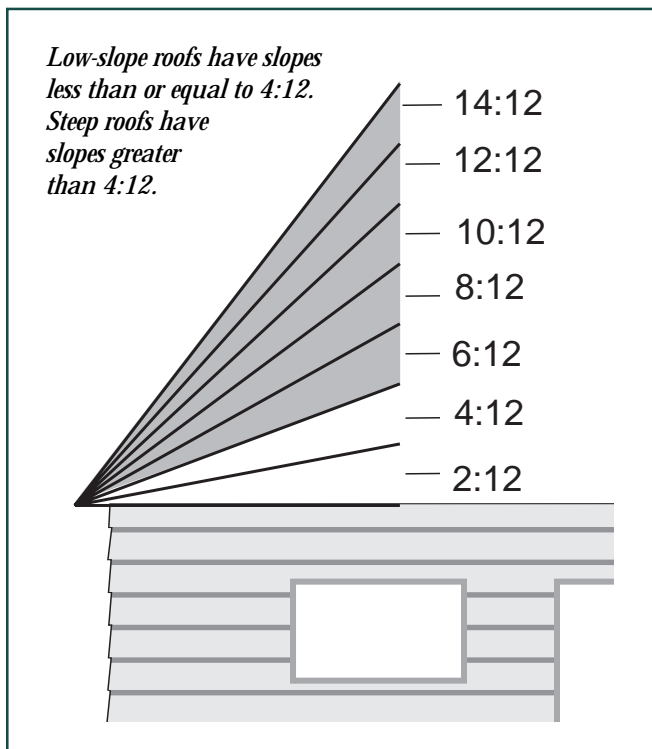

Steep roofs — Roofs with slopes greater than 4:12

If you do roofing work on a steep roof with unprotected sides and edges, and you are six feet or more above a lower level, you must use one of the following fall-protection systems:

- Guardrail system with toeboards
- Safety-net system
- Personal fall-arrest system
- Roof brackets and slide guards (residential-type structures only)

If you are working on the roof of a residential-type structure, you can work up to 10 feet above a lower level before you need fall protection.

IV. Fall-protection systems and methods

A fall-protection system refers to equipment designed to control fall hazards. Fall-protection systems either prevent falls from occurring or safely arrest falls. Typical fall-protection systems include the following:

- Personal fall-arrest systems
- Guardrail systems
- Safety-net systems
- Warning-line systems
- Safety-monitoring systems
- Controlled-access zones

Conventional fall protection

Personal fall-arrest systems, guardrail systems, and safety-net systems — the most common fall-protection systems — are called *conventional fall protection*. Warning lines, safety-monitoring systems, and controlled-access zones have special applications. Other fall protection methods used for roofing work include slide guards and covers.

The personal fall-arrest system

A personal fall-arrest system consists of an *anchor*, *connectors*, and a *body harness* that work together to stop one from falling and to minimize the arrest force. Other system components may include a *lanyard*, a *deceleration device*, and a *lifeline*. However, the personal fall-arrest system is effective only if you know how the system components arrest a fall. OR-OSHA's design and performance requirements for personal fall-arrest systems are in Division 3, Subdivision M, 1926.502(d).

Personal fall-arrest system components

The anchor

An anchor provides a secure point of attachment for a lifeline, lanyard, or deceleration device and is perhaps the most important personal fall-arrest system component. It must support a minimum load of 5,000 pounds — a challenging requirement, particularly on wood-framed and residential-type structures. If you don't know the weight an anchor point will hold, you should have a *qualified person* design a complete fall-protection system. The system must be installed under the supervision of the qualified person and it must maintain a *safety factor* of at least two — twice the impact force of a worker free falling six feet. OR-OSHA

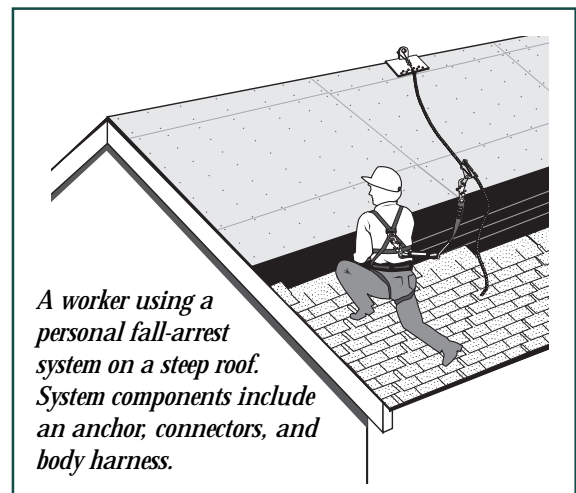

Qualified person

Safety factor

defines a qualified person as “one who, by possession of a recognized degree, certificate, or professional standing, or who by extensive knowledge, training, and experience, has successfully demonstrated the ability to resolve problems relating to a specific subject, operation, or project.”

Never use hoists or guardrails as anchors. They are not built to withstand the impact forces generated by a fall.

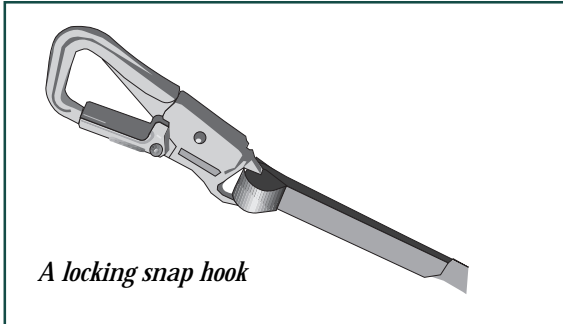

Connectors

Connectors couple the components of a personal fall-arrest system. *D-rings* and *snap hooks* are the most common types of connectors. Connectors must be drop-forged, pressed, or made from formed steel or equally strong material. They must be corrosion-resistant, with smooth surfaces and edges that won't damage other parts of the personal fall-arrest system.

The D-ring, a body-harness component, attaches to a deceleration device or to a lanyard. D-rings must have a minimum breaking strength of 5,000 pounds.

Non-locking snap hooks are prohibited as part of a personal fall-arrest system.

The snap hook consists of a hook-shaped member and a keeper. It opens to snap onto another component and when released, automatically closes. Snap hooks must also have a minimum breaking strength of 5,000 pounds. There are two types of snap hooks, locking and non-locking. The locking type has a self-locking keeper that won't open until it's unlocked. OR-OSHA has determined the non-locking type is not safe. **Use only locking snap hooks as part of a personal fall-arrest system.**

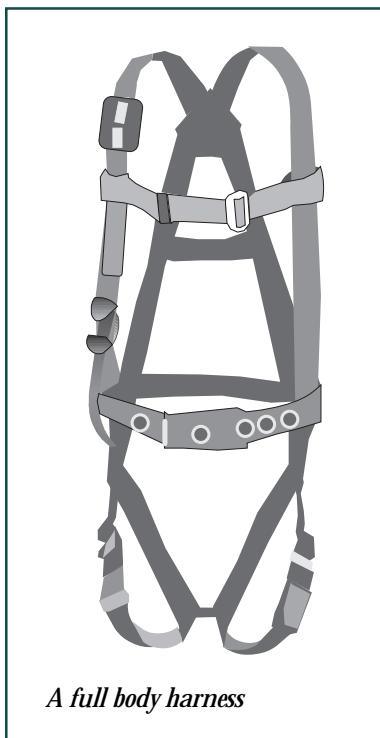

The body harness

The body harness consists of straps that distribute fall-arrest forces over the thighs, waist, chest, shoulders, and pelvis. Body harnesses come in many styles most of which are light and comfortable. A basic harness should include a back D-ring for attaching lifelines, lanyards, or retractable devices and a back pad for support. A body harness must exert an arresting force of no more than 1,800 pounds on a falling worker.

Remember the following when you use a body harness:

- Body harnesses cannot be made from natural fibers.
- Body harnesses are available in different sizes. Make sure the harness fits properly.
- The attachment point of a body harness must be located in the center of the back, about shoulder level.
- Use only body harnesses approved for commercial work. Do not use recreational climbing harnesses.

Lanyards

A lanyard is a specially designed rope, strap, or webbing that connects a body harness to an anchor, a deceleration device, or a lifeline. Lanyards must have a minimum breaking strength of 5,000 pounds. Lanyards come in a variety of designs including self-retracting types that make moving about easier and shock-absorbing types that reduce fall-arrest forces.

Remember the following when you use a lanyard:

- Self-retracting lanyards that limit free-fall distance to two feet or less must have components that will hold a minimum load of 3,000 pounds with the lanyard in the fully extended position.
- Self-retracting lanyards that do not limit free-fall distance to two feet or less must have components that will hold a minimum load of 5,000 pounds with the lanyard in the fully extended position.
- When using self-retracting lanyards that do not limit free-fall distance to two feet or less, work near or directly below the anchor to avoid a *swing fall*. (See Page 11 for more information on swing falls.)
- Do not use rope lanyards made from natural fibers.

Deceleration devices

You can reduce fall-impact forces on an anchor (and yourself) by minimizing the fall distance and using a deceleration device, such as a shock-absorbing lanyard or self-retracting lifeline. A third type of deceleration device is the *rope grab*, a mechanism that allows you to move up and down a vertical lifeline. The rope grab automatically locks onto the lifeline if you fall. Always follow manufacturers' instructions when you use deceleration devices.

Lifelines

A lifeline is flexible cable or rope that connects to a body harness, lanyard, or deceleration device and at least one anchor. There are two types of lifelines, *vertical* and *horizontal*.

A vertical lifeline attaches directly to a body harness, lanyard, or deceleration device and to an anchor (and hangs vertically, hence the name). Vertical lifelines must have a minimum breaking strength of 5,000 pounds.

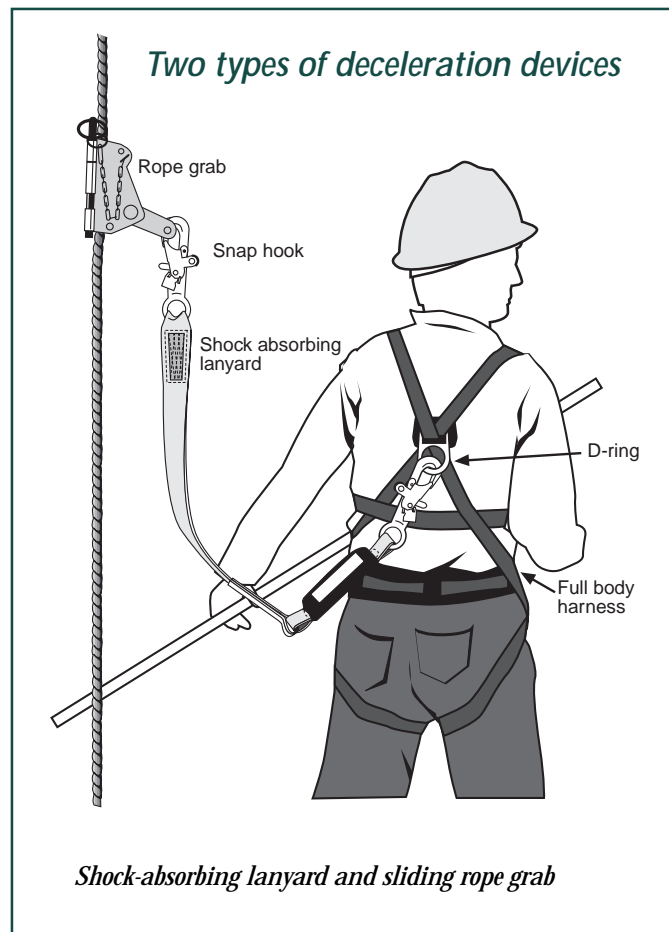

The *self-retracting lifeline* is both a vertical lifeline and a deceleration device. It consists of a drum-wound line that unwinds and retracts from the drum as a worker moves. If the worker falls, the drum automatically locks. Self-retracting lifelines that automatically limit free-fall distance to two feet or less must have a minimum breaking strength of 3,000 pounds. Self-retracting lifelines that do not limit free-fall distance to two feet or less must have a minimum breaking strength of 5,000 pounds.

If you need to move horizontally over an extended distance, however, the vertical lifeline can be hazardous because it creates the potential for a swing fall — a pendulum motion that results when you swing back under the anchor point. (See Page 11 for more information on swing falls.)

Unlike the vertical lifeline, the horizontal lifeline stretches between two anchors. When you connect to the line with a body harness, lanyard, or deceleration device, you can move freely across a flat surface. Horizontal lifelines and their anchors are subject to greater loads than vertical lifelines, however. If not anchored correctly, horizontal lifelines can fail at the anchor points. For these reasons, horizontal lifelines must be designed, installed, and used under the supervision of a qualified person as part of a complete personal fall-arrest system that maintains a safety factor of at least two (twice the potential impact force of a worker free falling six feet). For more information, see *Understand horizontal lifeline forces*, Page 11.

Keep in mind that a vertical lifeline must support at least 5,000 pounds and a horizontal lifeline must support at least 5,000 pounds per attached worker. Protect all lifelines against cuts or abrasions and never use lifelines made from natural fiber rope; the fibers deteriorate.

After a fall-arrest system stops a fall, remove it from service immediately and do not use it until a competent person determines that it's safe. OR-OSHA defines a *competent person* as "one who is capable of identifying existing and predictable hazards in the work environment and who has authorization to take prompt measures to eliminate the hazards."

Competent person

Guidelines for using personal fall-arrest systems

Plan anchor points

Try to anticipate anchor locations before construction work begins. It's possible to design anchors into a building for window cleaning or other maintenance tasks, for example. During the construction phase, workers can use planned anchors too. A qualified person must design anchor systems installed during construction.

Avoid knots in rope lanyards and lifelines

Knots can reduce the strength of a lifeline or a lanyard by 50 percent or more. Avoid using knots for tying off to an anchor; use a locking snap hook designed for that purpose.

Avoid tying lifelines or lanyards directly to an I-beam

By tying a rope lanyard or lifeline around an I-beam, you reduce the rope's strength by 70 percent due to the cutting action of the beam edges. Avoid "tie-offs" around I-beams and any other rough or sharp objects. Use *tie-off adapters* or *beam connectors* to anchor a lifeline or lanyard to the beam.

Understand horizontal lifeline forces

Designing and installing horizontal lifeline anchors are critical activities. The reason is related to the geometry of the horizontal lifeline (anchored at each end) and its *sag angle*, which is the line's angle of deflection when subjected to a load. Reducing the sag angle on a horizontal lifeline increases the forces imposed on the line during a worker fall. For example, a horizontal lifeline with a 15-degree sag angle will receive twice the impact force as a horizontal lifeline with a 30-degree sag angle. If you decrease the sag angle to five degrees, the impact force increases by a factor of six.

Sag angle

Two workers can connect to the same horizontal lifeline. If one worker falls, however, the line movement could cause the other worker to fall, subjecting the line and anchors to an even greater impact. For these reasons, horizontal lifelines must be designed, engineered, and installed under the supervision of a qualified person.

Be cautious with eyebolt connections

The strength of an eyebolt is rated along the axis of the bolt, and it's greatly reduced when force is applied at an angle to the axis. Avoid connections to eyebolts that might cause such an effect during a fall.

Consider total fall distances

Personal fall-arrest systems are designed to stop workers who experience *free falls*. Free fall is the part of the fall before the arrest system starts to take effect. However, even after the system activates, a worker will continue to fall. The distance a worker falls includes the free-fall distance, the lifeline's stretch from the force of the fall, and the deceleration distance required to absorb shock. OR-OSHA limits free-fall distance to six feet (less if a worker could strike an object or lower level). Lifeline stretch and deceleration distance cannot exceed 3.5 feet. Therefore, a worker wearing a personal fall-arrest system could fall up to 9.5 feet before stopping (six feet plus 3.5 feet). OR-OSHA requires that personal fall-arrest systems be rigged so that workers don't free fall more than six feet or strike a lower level.

*Free-fall distance is limited to six feet.****Avoid swing falls***

If you use a personal fall-arrest system and are not working directly below the tie-off anchor, you will swing back under the anchor during a fall. Swing falls are especially hazardous because you can hit an object or a lower level during the pendulum motion.

Remember the following about swing falls:

- Fall distance can actually increase during a swing fall.
- The impact force from a swing fall can be the same as it would be for a vertical fall with the same change of elevation.
- During a swing fall, you can strike an object or lower level before the arrest system stops your fall.

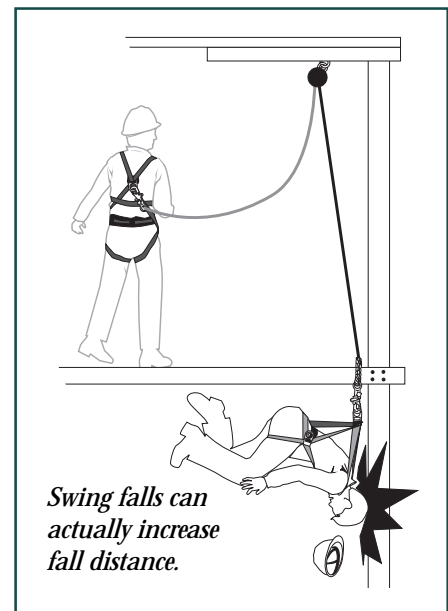

Guardrail systems

Guardrail systems are vertical barriers consisting of top rails, *midrails*, and intermediate vertical members. Guardrail systems can also be combined with toeboards, which are barriers that prevent materials and equipment from dropping to lower levels. You can use guardrail systems without toeboards for fall protection on low-slope roofs. On steep roofs, use guardrail systems with toeboards. OR-OSHA's design and performance requirements for guardrail systems are in Division 3, Subdivision M, 1926.502(b), and include the following:

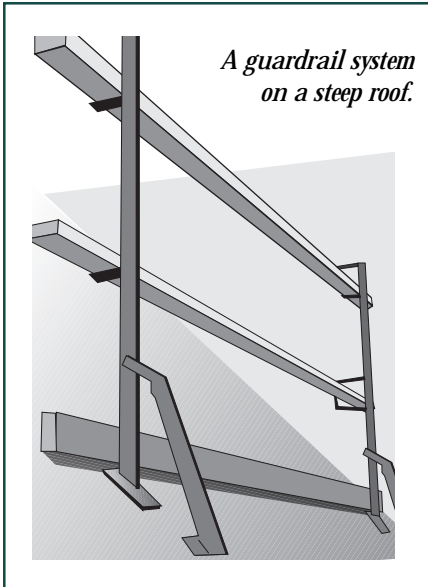

- Guardrail systems must be free of anything that might cut a worker or snag a worker's clothing. All guardrails must be at least one-quarter-inch thick to reduce the risk of hand lacerations. Steel or plastic banding is not permitted for top rails or midrails.
- Wire rope used for a top rail must be marked at least every six feet with high-visibility material.
- The top edge of a guardrail system must be 42 inches, plus or minus three inches, above the surface to which it is attached. The top-edge height can exceed 45 inches when conditions warrant; however, the guardrail system must meet all other performance criteria.

- Where there is no wall or parapet at least 21 inches high, screens, mesh, midrails, or similar protection must be installed between the top edge of the guardrail system and the working surface. Midrails must be installed midway between the top edge of the guardrail system and the working surface. Screens or mesh must extend from the top rail to the working surface.
- Intermediate vertical members, between posts, must be no more than 19 inches apart.
- The guardrail system must be capable of withstanding a 200-pound force applied within two inches of its top edge, in any outward or downward direction. Midrails, screens, and intermediate structural members must withstand at least 150 pounds applied in any downward or outward direction.

Properly constructed, catch platforms are an acceptable means of fall protection.

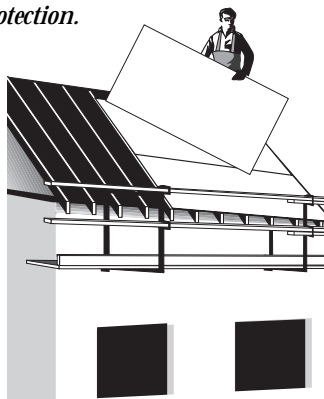

Frequently asked question

Are "catch platforms" acceptable fall protection for roofing work? If so, what are OR-OSHA's requirements for the platform?

Though not identified as a means of fall protection in Subdivision M, catch platforms offer effective protection. The platform must extend outward two feet beyond the eaves and it must have a standard guardrail and toeboard. The guardrail must extend far enough above the roof edge to prevent one from falling to a lower level.

Safety-net systems

Safety-net systems consist of mesh nets, panels, and connecting components. They're typically used as protection for those who work on bridges and similar structures. Safety-net systems are rarely used for roofing work.

Other fall-protection systems

Warning-line systems

Warning-line systems consist of ropes, wires, or chains and supporting stanchions that form a barrier to warn those who approach an unprotected roof side or edge. The warning lines mark off an area within which one can do roofing work without using guardrails or safety nets; warning-line systems can be combined with guardrail systems, personal fall-arrest systems, or safety-monitoring systems to protect those doing roofing work on low-slope roofs (4:12 or less).

A combined warning-line system and safety-monitoring system provides practical, effective fall protection for roofing work on low-slope roofs. Warning-line systems on low-slope roofs are also effective for protecting those who don't need to work near an unprotected edge.

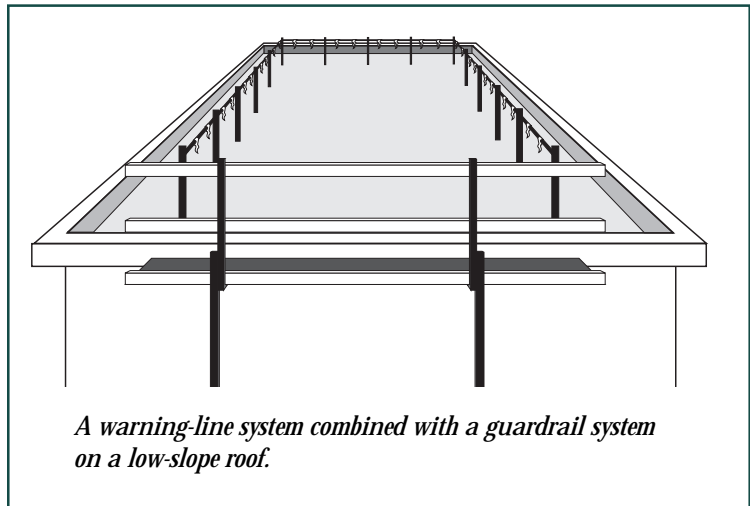

A warning-line system combined with a guardrail system on a low-slope roof.

If you decide to use warning lines, keep the following in mind:

- Set up the warning line around all exposed sides of the roof, six feet from the edge.
- Make sure the line has a minimum 500-pound tensile strength.
- Mark the line with high-visibility material every six feet.

The design and performance requirements for warning-line systems are covered in Division 3, Subdivision M, 1926.502(f).

Frequently asked question

Can I use standard plastic caution tape or ribbon for the warning line?

No. The warning line must have enough strength so that one who leans against the line will not break it. Subdivision M, paragraph 1926.502(f) states that only rope, wire, or chain with a minimum strength of 500 pounds may be used as a warning line.

Safety-monitoring systems

A safety-monitoring system is a set of procedures assigned to a competent person for monitoring and warning workers who may be unaware of fall hazards. Safety-monitoring systems are appropriate for roofing operations on low-slope roofs less than 50 feet wide. You can use a safety-monitoring system combined with a warning-line system on low-slope roofs with larger dimensions. A safety-monitoring system combined with a controlled-access zone and a *fall-protection plan*, is acceptable for situations where conventional fall protection is not feasible. (For information on the fall protection plan, see Page 21.) Keep in mind that a safety-monitoring system consists of fall-protection procedures rather than a substantial barrier.

Division 3, Subdivision M, 1926.502(h), includes the design and performance requirements for safety-monitoring systems.

Controlled-access zones

The controlled-access zone defines an area where workers can do *leading-edge, overhand bricklaying and related work, or work under a fall-protection plan*, without using conventional fall protection. All others are prohibited from entering a controlled-access zone. You can use a controlled-access zone as fall protection for leading-edge work or residential-type construction work only as part of a fall-protection plan. You must also include a safety monitor to warn those working within the zone of fall hazards. (For information on the fall protection plan, see Page 21.) The control zone consists of a line, or lines, warning workers that access to the zone is restricted to authorized persons. Control lines must meet the following criteria:

- Consist of ropes, wires, tapes, or equivalent materials and supporting stanchions
- Be flagged at least every six feet with high-visibility material
- Be no less than 39 inches from the working surface at its lowest point and no more than 45 inches from the working surface at its highest point (50 inches in overhand bricklaying operations)
- Have a minimum breaking strength of 200 pounds

Division 3, Subdivision M, 1926.502(g), includes the design and performance requirements for controlled-access zones.

Roof brackets and slide guards

Roofers who install sheathing and related materials frequently use roof brackets and slide guards for fall protection. OR-OSHA permits roofers to use 2"x 6" roof brackets and slide guards for fall protection on *residential-type structures under the following conditions*:

- On roofs sloped 3:12 through 6:12, the ground-to-eave height must not exceed 25 feet.
- On roofs sloped greater than 6:12 and less than or equal to 8:12, the ground-to-eave height must not exceed 25 feet and the roof brackets and

slide guards must be used in multiples, spaced no more than every eight feet vertically. **All roof brackets and slide guards must bear on solid surfaces.**

- The roof bracket and slide guard at the lower edge of the slope must be at least six inches from the roof edge and perpendicular to the roof surface. Other brackets and slide guards above the lower edge may be installed at a 60-degree angle to the roof surface. **All roof brackets and slide guards must bear on solid surfaces.**

Guidelines for using roof brackets and slide guards

- Use a personal fall-arrest system, ladder, or a scaffold to install and position the row of brackets and slide guards closest to the roof edge. If you use a personal fall-arrest system and you don't know how much the anchor will hold, (it must support 5,000 pounds) have it checked by a qualified person.
- If you install roof brackets and slide guards on tile roofs, make sure they extend high enough above the tile surface to protect a worker in an uncontrolled slide. (For example, use 2" x 8" instead of 2" x 6" members.)
- To properly support the upright member, space the roof brackets no more than eight feet apart horizontally.
- If you are doing work that involves leaning over the edge of a residential-type structure, and the distance to a lower level is greater than 10 feet, you need additional fall protection. A personal fall-arrest system provides the most effective protection, but you must be able to connect it to a secure anchor.
- Remove roof brackets and slide guards from the top of the roof and work down the slope. The lower slide guards will protect you from falling.
- If you can connect to a secure anchor, use a personal fall-arrest system to remove roof brackets on steep roofs.

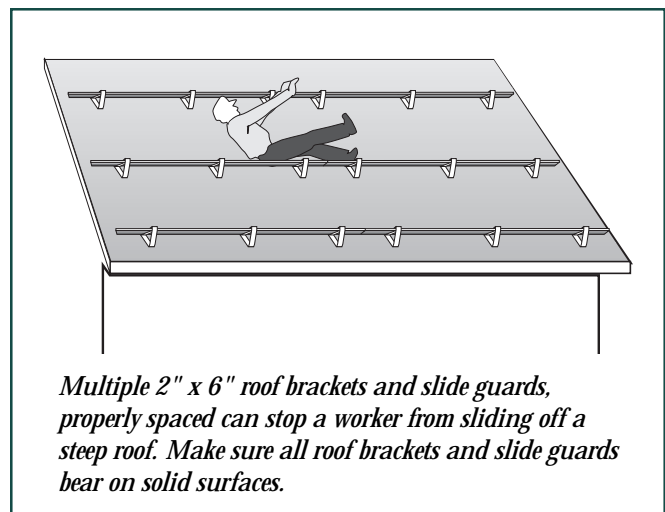
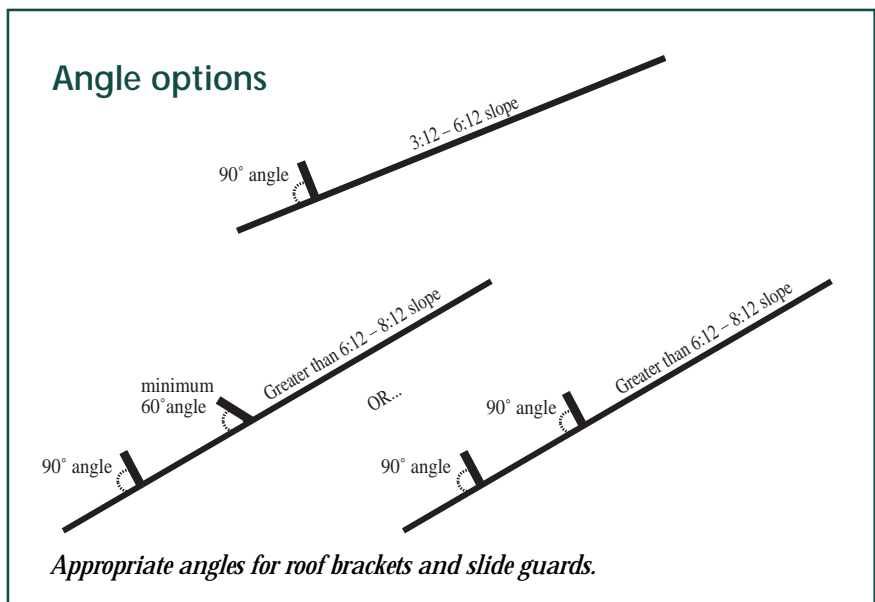

- Use a ladder or scaffold to remove the row of brackets and slide guards closest to the roof edge.
- Install roof brackets and slide guards under the direction of a competent person.

Frequently asked question

I'm laying roof sheathing up a sloped roof and using slide guards for protection. Do I need additional fall protection if the fall distance from the leading edge to the building interior is 10 feet or more?

If you're laying sheathing such plywood or straw board panels, the panels are probably supported. If you're moving the panels up the roof slope, you're not likely to fall to the interior. However, if your work — such as laying 2" x 6" tongue-and-groove decking — exposes you to a fall hazard, you'll need additional protection to control the hazard.

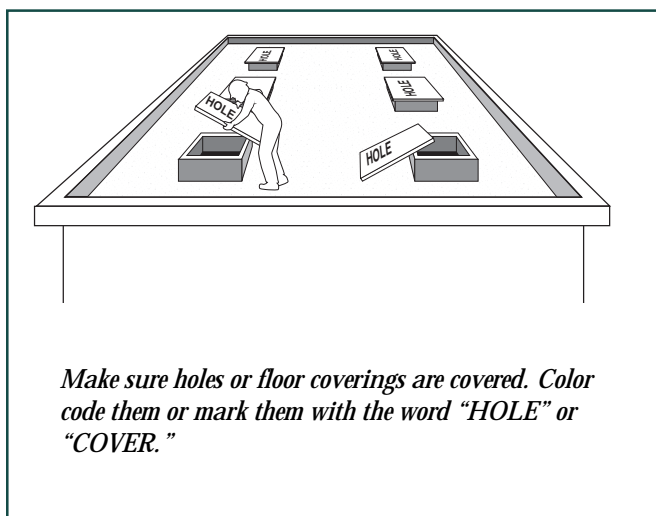

Covers

A cover includes any rigid object used to overlay openings in floors, roofs, and other walking and working surfaces. Covers must be able to support at least twice the maximum anticipated load of workers, equipment, and materials. Covers should have full-edge bearing on all four sides. Make sure covers are secure and color-code or mark them with the word "HOLE" or "COVER." Division 3, Subdivision M, 1926.502(i), includes the design and performance requirements for covers.

Summary: fall-protection options for roofers

The table below shows the fall-protection systems and methods acceptable for roofing work under Division 3, Subdivision M requirements. Roofers who do residential-type construction work have the widest range of fall-protection options. Roofers who work on nonresidential structures with steep roofs must use conventional fall protection — guardrails, safety nets, or personal fall-arrest systems.

Fall protection acceptable for roofing work under Division 3 Subdivision M requirements	Low-slope: less than or equal to 4:12		Steep: greater than 4:12	
	Residential-type construction (fall protection required 10 feet or more above a lower level)	Nonresidential construction (fall protection required 6 feet or more above a lower level)	Residential-type construction (fall protection required 10 feet or more above a lower level)	Nonresidential construction (fall protection required 6 feet or more above a lower level)
Guardrail systems with toeboards	✓	✓	✓	✓
Safety net systems	✓	✓	✓	✓
Personal fall arrest systems	✓	✓	✓	✓
Warning line and guardrail systems	✓	✓		
Warning line and safety net systems	✓	✓		
Warning line and personal fall arrest systems	✓	✓		
Warning line and safety monitor systems	✓	✓		
Safety monitoring systems only	✓ (permits only on roofs 50 feet or less in width)	✓		
Fall protection plan (can only be used when conventional systems are infeasible or create a greater hazard)	✓		✓	
Roof brackets (single row)	✓ (slope 3:12 through 6:12)		✓ (slope 3:12 through 6:12)	
Roof brackets (rows, spaced no more than every 8 feet vertically)			✓ (slope greater than 6:12 through 8:12)	

V. Working safely with ladders

Division 3,
Subdivision X

Within the construction industry, falls from ladders account for many fall-from-elevation injuries. Most injuries associated with the falls result from slips, loss of footing, and unstable ladders. OR-OSHA's safety requirements for ladders are in Division 3, Subdivision X; the following are relevant to roofing work:

Coated wood ladders

Do not coat wood ladders with any opaque covering except for identification or warning labels placed only on one face of a side rail.

Ladder surfaces

Ladders must have surfaces that will not cut workers or snag their clothing.

Load capacities

Self-supporting portable ladders must be able to support at least four times their maximum intended loads. (Maximum intended load means the combined weight of workers, equipment, tools, and materials.)

Rungs, cleats, and steps

Ladder rungs, cleats, and steps must be parallel, level, and uniformly spaced not less than 10 nor more than 14 inches apart. Rungs and steps must be shaped or treated to minimize slipping.

Spreaders and locking devices

A metal spreader or locking device is required to hold the front and back section of a stepladder in an open position when the ladder is in use.

Ladders tied together

Do not tie or fasten ladders together to make longer sections unless they are designed for that purpose.

Using two or more ladders

Two or more separate ladders used to gain access to an elevated work area must be offset with a platform or a landing between them.

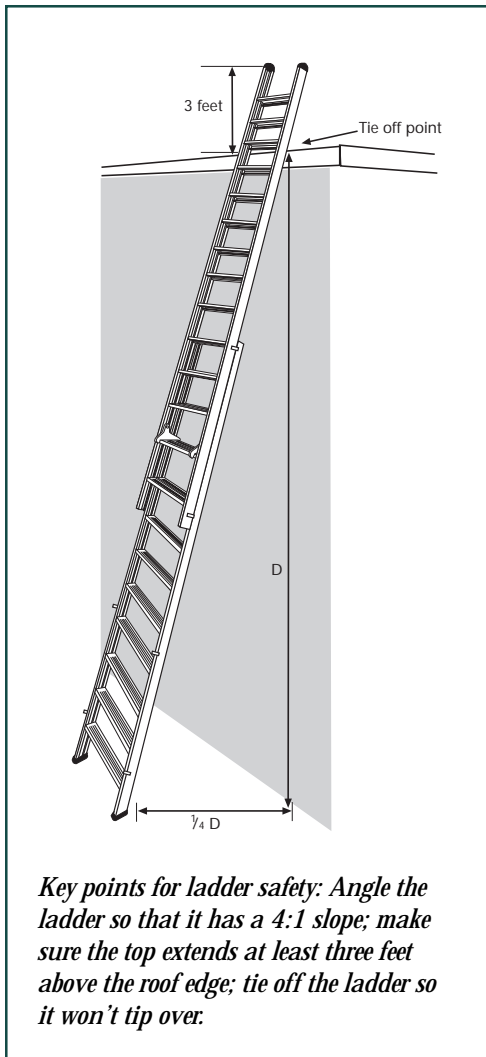

Key points for ladder safety: Angle the ladder so that it has a 4:1 slope; make sure the top extends at least three feet above the roof edge; tie off the ladder so it won't tip over.

Training requirements

Workers who use ladders must receive training that covers the following:

- The nature of fall hazards in the work area
- The proper construction, use, placement, and care of the ladders
- The maximum intended load-carrying capacities of the ladders
- The requirements in Subdivision X for the ladders workers will use

Safe practice guidelines for working with ladders

You can reduce your risk of falling from a ladder by observing the following guidelines:

- Select a ladder that's appropriate for your task. It must extend at least three feet above the access area.
- Inspect the ladder before using it; it should be dry, clean, and undamaged.
- Angle the ladder properly; position the base so that the distance to the building is less than one-fourth the ladder's length. The minimum slope should be 50 degrees.
- Protect the base of the ladder so that people or vehicles won't strike it.
- Face the ladder and keep both hands on the side rails while climbing and descending.
- Raise and lower heavy loads with a hand line or hoist. Avoid carrying them up or down a ladder.
- Make sure metal ladders have steps and rungs with skid-resistant surfaces.
- Allow only one person to work from a ladder; use a scaffold when two or more people must work together.
- Don't stand on the top step of a portable ladder.
- Keep ladders with conductive side rails away from exposed, electrical equipment.

A sample fall-protection plan

ABCDE Building Inc.
 12345 Main St.
 Salem, OR 97301

This Fall Protection Plan is specific for the following project:

Location of job: 6789 First St. Salem, Oregon

Date plan prepared or modified: June 1, 1999

Plan prepared by: Tom Smith

Plan approved by: [Ted Cook, qualified person]

Plan supervised by: Jane Jones

Statement of company policy: ABCDE Building is dedicated to protecting employees from workplace injuries and illnesses. Company management and supervisors are responsible for identifying and correcting hazards on the job. All employees are responsible for working safely. This plan supplements our existing safety and health program.

This plan addresses the use of conventional fall protection at a number of areas on this project and identifies specific activities that require unconventional means of fall protection. These activities include:

- Setting and bracing roof trusses and rafters
- Installation of floor sheathing and joists
- Roof sheathing operations
- Erecting exterior walls

Each employee will be trained in these procedures and will strictly adhere to them except when doing so would expose the employee to greater hazards. If, in the employee's opinion, this is the case, the employee is to notify the competent person of his or her concern and have the concern addressed before proceeding.

It is the responsibility of the [Jack Black, competent person] name to implement this Fall Protection Plan. Work operations will be checked frequently and safety policy and procedures will be enforced. The crew foreman, Jane Jones, is responsible for correcting unsafe practices or conditions immediately.

It is the responsibility of the employer to ensure that all employees understand and adhere to the procedures of this plan and follow the instruction of the crew supervisor. It is the responsibility of the employee to alert management to unsafe or hazardous conditions or practices that may cause injury to employees. Any changes to the Fall Protection Plan must be approved by [Ted Cook, qualified person].

Fall protection systems to be used on this job: Installation of the roof trusses/rafter, exterior wall erection, roof sheathing, floor sheathing and joist/truss activities will be conducted by employees trained to do this type of work and trained to recognized the fall hazards. This plan details how ABCDE Building will minimize these hazards.

VI. Using a fall-protection plan

A fall-protection plan enables workers doing *leading-edge work, precast concrete erection work, or residential-type construction work* to use alternative fall-protection systems or methods when conventional systems aren't feasible. Under these special circumstances, properly documented fall-protection plans give employers the flexibility to use more appropriate methods of fall protection. However, employers must be able to show that conventional systems are not practical or that they pose a greater safety hazard to workers than other fall-protection alternatives. In addition, the fall-protection plan must meet the following requirements:

Fall-protection plan requirements

- A qualified person must prepare the plan specifically for the site where the work will be performed.
- The plan must document why conventional fall-protection systems are not feasible and show how alternative methods will reduce or eliminate fall hazards.
- The plan must describe all measures that will be taken to minimize or eliminate fall hazards at the worksite.
- The employer must designate the work area as a controlled-access zone.
- Employers who do not use either alternative fall-protection measures or conventional systems must use a safety-monitoring system to protect workers in the controlled-access zone.

OR-OSHA's requirements for fall-protection plans are covered in Division 3, Subdivision M, 1926.502(k).

An effective fall-protection plan can protect workers from fall hazards and enhance the overall level of safety at a job site. *If you decide to develop a fall-protection plan, use the following guidelines to keep your plan in line with OR-OSHA's requirements. OR-OSHA will use these guidelines to verify that your plan meets the intent of 1926.502(k).*

Explain why you can't use conventional systems

Before you can use a fall-protection plan, you must explain why conventional protection methods – guardrails, safety nets, personal fall-arrest, or fall-restraint systems – are infeasible or would pose a greater safety hazard to workers than your proposed method. Consider using scaffolds, catch platforms, or aerial lifts. If you can't eliminate the hazard, you must also explain why. Be specific! The following three examples help illustrate the point.

- If anchors capable of holding 5,000 pounds are not available you must also explain why personal fall-arrest systems with 2:1 safety factors or fall-restraint systems will not protect workers.
- If you believe that having workers erect guardrails creates a greater hazard than an alternative method, you must explain why. You must

demonstrate why erecting and dismantling guardrail systems creates a greater hazard than your alternative method and why you can't use personnel platforms, personal fall-arrest, or fall-restraint systems.

- If you feel that guardrail systems are not feasible because you can't anchor them in a finished surface, you must also consider free-standing guardrail systems that don't put holes in the finished surface. If you can't use free-standing systems, you must explain why.

Describe how your alternative method will protect workers

Describe specifically how your alternative fall-protection method will reduce or eliminate fall hazards. Include workers' tasks, the fall hazards they'll encounter, the location of hazards, and how you intend to protect them from the hazards. You can list your responses in a table such as the one below.

<i>How alternative fall-protection methods will reduce or eliminate fall hazards</i>			
The worker's task	The type of fall hazard (such as a floor opening or unprotected edge)	The location of the fall hazard	Alternative protection (how it will reduce or eliminate the fall hazard)

Appoint a qualified person to prepare the plan

A qualified person is one who has extensive knowledge, training, and experience with fall-protection systems. A qualified person must know how to design, use, and install fall-protection systems; the limitations of fall-protection systems; and fall hazards associated with work tasks and processes. A qualified person must prepare a site-specific fall-protection plan and approve any changes to the plan. Be sure that the plan identifies the following:

- The construction activity (leading-edge, residential, or precast concrete erection)
- The site address where you will use the plan
- The name of the person who prepared the plan (must be a qualified person)
- The date the qualified person prepared the plan

Establish controlled-access zones where you can't use conventional protection

Your fall-protection plan must identify each area where you can't use guardrails, safety nets, or personal fall-arrest systems, and you must designate those areas as controlled-access zones. In addition, you must do the following:

- Describe how you will limit access to controlled-access zones, including procedures that authorize workers to enter controlled-access zones.
- Describe how you will identify controlled-access zones and how you will separate them from other work areas.
- Identify all workers who will enter controlled-access zones.

Assign supervisory responsibility to a competent person

A competent person is someone who can identify hazardous conditions and appropriate applications for a fall-protection system and who has authority to correct hazards. A competent person must know the site-specific fall-protection plan, how to perform work tasks safely, and the hazards associated with those tasks. You must designate a competent person to implement the fall-protection plan.

Document accountability

Your fall-protection plan must describe how workers and supervisors will comply with its requirements.

Establish a training program

Everyone covered by a fall-protection plan must be trained by a competent person. Be sure to document the names of those who receive fall-protection training and their training dates. The training program must cover the following:

- Fall hazards that workers will encounter
- Types of systems that will protect workers from falls
- Workers' responsibilities under the fall-protection plan
- Procedures for assembling, maintaining, and disassembling personal fall-arrest systems
- How workers should comply with the plan
- Retraining procedures when the plan changes, tasks change, or when workers are not following the plan

Update the plan when site conditions change

When worksite conditions change and affect how workers are protected from falling, you must update your fall-protection plan so that it addresses the changes. An on-site qualified person must approve the changed plan. The updated plan must:

- Describe the site-condition changes that required the update
- Include the qualified person's reasons for the update
- Include the date the qualified person approved the plan changes and the person's signature

Investigate accidents

If a worker covered by the fall-protection plan fell or had a "near miss" incident, you must investigate the accident and, if necessary, change the plan so that similar events will not happen again. The plan must describe near misses or accidents and how to prevent future incidents.

Keep the plan at the job site

You must keep a copy of the fall-protection plan, with all approved changes, at the job site.

VII. Fall-protection training

If you're an employer, you need to be aware of fall hazards in your workplace and you must take appropriate action to minimize those hazards. Selecting appropriate fall protection is the first step toward meeting that responsibility. The second step is training workers so they are familiar with the fall-protection systems or methods they use. Division 3, Subdivision M, 1926.503, requires employers to provide training for all workers exposed to fall hazards. A competent person must provide training that ensures workers will recognize fall hazards and that they will use appropriate procedures to minimize exposure to the hazards.

Employer responsibilities

In addition, workers who use personal fall-arrest systems must also know:

- How to wear the equipment
- The proper hook-up and attachment methods for the equipment
- Appropriate anchoring and tie-off techniques
- How to estimate free-fall distances
- Inspection and storage procedures for the equipment
- Self-rescue procedures and techniques

Retraining

Workers who do not recognize fall hazards at a particular work area must be retrained. Other reasons for retraining include changes at a worksite that make earlier training obsolete, changes in the types of fall-protection equipment used by workers, or a worker's failure to use fall-protection equipment effectively.

Certification

Employers must maintain a written record of each worker's fall-protection training. The record must document the worker's name, the date the worker was trained, and the trainer's signature.

In the Appendix, you'll find checklists and a training certification form to help you track fall hazards and fall-protection systems at your worksite. Use the checklists to identify fall hazards and fall-protection systems. Use the form to certify workers who have been trained to identify workplace fall hazards and to use fall-protection systems effectively.

Look for fall-protection checklists and a training certification form in the Appendix.

VIII. Preparing for emergencies

The employer must ensure that any worker who falls is promptly rescued.

Fall-protection systems are designed to minimize workers' exposure to fall hazards and to reduce their risk of injury if they do fall. Nevertheless, employers must establish procedures to ensure that workers who fall receive prompt emergency and medical attention. Emergency procedures should identify key rescue and medical personnel, equipment available for rescue, emergency communications procedures, retrieval methods, and primary first-aid requirements.

Workers in 911 service areas can use this number for ambulance service; however, most 911 responders are not trained to rescue an injured worker suspended in a personal fall-arrest system. Emergency procedures must ensure the prompt rescue of a suspended worker. The 911 number does not ensure a prompt rescue.

Use the following guidelines to develop your emergency response procedures.

Before on-site work begins

Make fire department or other emergency responders aware of any conditions at the site that may hinder a rescue effort.

- Document rescue procedures and make sure they're posted at the worksite.
- Post emergency-responder phone numbers and addresses at the worksite.
- Mark the worksite with signs noting the easiest routes in and out of the site.
- Make sure responders have quick access to rescue and retrieval equipment such as lifts and ladders.

As on-site work progresses

- Identify on-site equipment that can be used for rescue and retrieval. Examples: aerial lifts, ladders, and forklifts.
- Maintain a current equipment inventory at the site. Equipment may change frequently as the job progresses.
- Re-evaluate and update the emergency response plan if on-site work tasks change.

If an emergency occurs

- Call 911 or other emergency numbers in the emergency-response plan. First responders should clear a path to the victim. Others should direct emergency personnel to the scene.
- Make sure only qualified personnel attempt a technical rescue.
- Prohibit all nonessential personnel from the fall-rescue site.
- Talk to the fall victim; determine the victim's condition, if possible.
- If the victim is accessible, make the victim comfortable and check vital signs. If necessary, administer CPR and attempt to stop bleeding.

Investigating an accident

- **Report fatalities and catastrophes to OR-OSHA within eight hours. Report injuries requiring overnight hospitalization and medical treatment other than first aid within 24 hours.**
- Identify all equipment associated with the accident and put it out of service until the investigation is finished.
- Document what went wrong, step by step.
- Review the fall-protection procedures; determine how the procedures could be changed to prevent similar accidents; revise the procedures accordingly.
- Have a competent person examine equipment associated with the accident. If the equipment is damaged, repair or replace it. If the equipment caused the accident, determine how and why.

Appendix: Fall-protection checklists and training certification form

Use this checklist to identify fall hazards at your worksite.

Fall-hazard checklist

Check all boxes that apply. Check “Yes” if hazards exist at your worksite; check “N/A” if not.

Hazard	Yes	N/A
Hoist areas	<input type="checkbox"/>	<input type="checkbox"/>
Holes	<input type="checkbox"/>	<input type="checkbox"/>
Formwork	<input type="checkbox"/>	<input type="checkbox"/>
Rebar	<input type="checkbox"/>	<input type="checkbox"/>
Runways	<input type="checkbox"/>	<input type="checkbox"/>
Excavations	<input type="checkbox"/>	<input type="checkbox"/>
Dangerous equipment	<input type="checkbox"/>	<input type="checkbox"/>
Overhand bricklaying	<input type="checkbox"/>	<input type="checkbox"/>
Floor joists and trussing	<input type="checkbox"/>	<input type="checkbox"/>
Floor sheathing	<input type="checkbox"/>	<input type="checkbox"/>
Erecting exterior walls	<input type="checkbox"/>	<input type="checkbox"/>
Roof trussing and rafting	<input type="checkbox"/>	<input type="checkbox"/>
Roof sheathing	<input type="checkbox"/>	<input type="checkbox"/>
Roofing	<input type="checkbox"/>	<input type="checkbox"/>
Wall openings	<input type="checkbox"/>	<input type="checkbox"/>
Falling objects	<input type="checkbox"/>	<input type="checkbox"/>

Use this checklist to identify the fall-protection system training each worker received at your worksite.

<i>Fall-protection systems checklist</i>									
Fall-protection system	Training received								
	N/A	Installation	Maintenance	Inspection	Disassembly				
Guardrail systems	<input type="checkbox"/>	<input type="checkbox"/>	<input type="checkbox"/>	<input type="checkbox"/>	<input type="checkbox"/>	<input type="checkbox"/>	<input type="checkbox"/>	<input type="checkbox"/>	<input type="checkbox"/>
Personal fall-arrest systems	<input type="checkbox"/>	<input type="checkbox"/>	<input type="checkbox"/>	<input type="checkbox"/>	<input type="checkbox"/>	<input type="checkbox"/>	<input type="checkbox"/>	<input type="checkbox"/>	<input type="checkbox"/>
Safety-net systems	<input type="checkbox"/>	<input type="checkbox"/>	<input type="checkbox"/>	<input type="checkbox"/>	<input type="checkbox"/>	<input type="checkbox"/>	<input type="checkbox"/>	<input type="checkbox"/>	<input type="checkbox"/>
Controlled-access zones	<input type="checkbox"/>	<input type="checkbox"/>	<input type="checkbox"/>	<input type="checkbox"/>	<input type="checkbox"/>	<input type="checkbox"/>	<input type="checkbox"/>	<input type="checkbox"/>	<input type="checkbox"/>
Roof brackets	<input type="checkbox"/>	<input type="checkbox"/>	<input type="checkbox"/>	<input type="checkbox"/>	<input type="checkbox"/>	<input type="checkbox"/>	<input type="checkbox"/>	<input type="checkbox"/>	<input type="checkbox"/>
Covers	<input type="checkbox"/>	<input type="checkbox"/>	<input type="checkbox"/>	<input type="checkbox"/>	<input type="checkbox"/>	<input type="checkbox"/>	<input type="checkbox"/>	<input type="checkbox"/>	<input type="checkbox"/>
Fences and barricades	<input type="checkbox"/>	<input type="checkbox"/>	<input type="checkbox"/>	<input type="checkbox"/>	<input type="checkbox"/>	<input type="checkbox"/>	<input type="checkbox"/>	<input type="checkbox"/>	<input type="checkbox"/>
Safety-monitoring systems	<input type="checkbox"/>	<input type="checkbox"/>	<input type="checkbox"/>	<input type="checkbox"/>	<input type="checkbox"/>	<input type="checkbox"/>	<input type="checkbox"/>	<input type="checkbox"/>	<input type="checkbox"/>
<p>Name of worker: _____</p>									

Definitions of selected terms

Anchor

A secure point of attachment for workers' lifelines, lanyards, or deceleration devices. Anchors must be capable of supporting a minimum load of 5,000 pounds per worker (or designed, installed, and used under the supervision of a qualified person, as part of a complete personal fall-arrest system which maintains a safety factor of at least two).

Barricade

An obstruction to deter the passage of persons or vehicles.

Body harness

Straps that an individual wears to distribute fall-arresting forces over the thighs, waist, chest, shoulders, and pelvis. Attaches to other components of a personal fall-arrest system. The maximum safe arresting force for a body harness is 1,800 pounds.

Competent person

A person who is capable of identifying existing and predictable hazards in the work environment and who has authorization to take prompt measures to eliminate the hazards.

Connector

A device used to couple (connect) components of a personal fall-arrest system. The connector may be an independent component (such as a carabiner) or an integral component (such as a buckle or D-ring) of the system. Connectors must be drop-forged or made of equivalent materials; they must have a corrosion-resistant finish and all surfaces and edges must be smooth to prevent damage to other parts of the system.

Controlled-access zone (CAZ)

An area designated for overhand bricklaying operations or leading edge construction. Conventional fall-protection systems — guardrail systems, personal fall-arrest systems or safety-net systems — are not required in a CAZ; access is restricted to all workers except those performing overhand bricklaying and leading-edge construction tasks.

Conventional fall protection

A guardrail system, safety-net system, or personal fall-arrest system

Cover

A rigid object used to overlay openings in floors, roofs, and other walking and working surfaces.

Deceleration device

Any mechanism that dissipates or limits energy imposed on a person during fall arrest. Examples include rope grabs, ripstitch lanyards, special woven lanyards, and automatic self-retracting lifelines.

Deceleration distance

The additional vertical distance a worker falls before stopping — excluding lifeline elongation and free-fall distance — from the point at which a deceleration device begins to operate. The distance is measured from the worker's body harness attachment point just before the device activates to the attachment point after the worker comes to a full stop.

D-rings

Attachment points on a body harness for deceleration devices or lanyards. D-rings must be capable of sustaining a minimum tensile load of 5,000 pounds.

Equivalent

Refers to an alternative design, material, or method that an employer can demonstrate will provide an equal or greater degree of safety for workers than the method or item specified in a standard.

Fall-protection plan

Enables workers doing leading-edge work, precast concrete erection work, or residential-type construction work to use alternative fall-protection systems or methods when conventional systems aren't feasible. To implement a fall-protection plan, employers must be able to show that conventional fall-protection systems are not practical or add to worker risk.

Fall-restraint system

A fall-protection system designed to physically prevent a worker from free falling. Components include a body harness, a rope or web lanyard, connectors, and an anchor. Fall-restraint systems are not covered in OR-OSHA's Subdivision M requirements for fall protection in the construction industry.

Free fall

Falling before fall protection begins to arrest the fall.

Free-fall distance

The vertical distance a worker falls before a personal fall-arrest system stops the fall; measured from the attachment point of the personal fall-arrest system immediately before and after the fall, excluding deceleration distance and lanyard and lifeline elongation, but including deceleration device slide distance or self-retracting lifeline/lanyard extension before fall-arrest forces occur.

Guardrail system

Vertical barriers erected to prevent workers from falling to a lower level.

Hole

Any opening more than two inches wide in a floor, roof, or other walking and working surface.

Infeasible

A situation in which it is not possible to perform construction work using a conventional fall-protection system.

Horizontal lifeline

A flexible horizontal cable or rope line anchored at both ends to which a worker's body harness or lanyard attaches. Horizontal lifelines must be designed, installed, and used under the supervision of a qualified person, as part of a complete personal fall-arrest system.

Lanyard

A flexible rope, strap, or webbing that connects body harness to a deceleration device, lifeline, or anchor. Lanyards that tie off one worker must have a minimum breaking strength of 5,000 pounds. Lanyards that automatically limit free-fall distance to two feet or less must have components capable of sustaining a minimum static tensile load of 3,000 pounds with the lanyard in the fully extended position.

Leading edge

The edge of a floor, roof, form work, or other walking and working surface that changes location as additional sections are placed. Leading edges not actively under construction are considered unprotected sides and edges.

Lifeline

A flexible line that attaches directly to a person's body harness, lanyard, or deceleration device at one end and to an anchor at the other end. A lifeline that hangs vertically and is connected to one anchor is a vertical lifeline. A lifeline that stretches horizontally between two anchors is a horizontal lifeline. All lifelines must be protected against cuts or abrasions. They cannot be made of natural fiber rope.

Lower level

Surface to which a worker can fall. Examples: ground levels, floors, ramps, runways, excavations, pits, tanks, material, water, and equipment.

Midrail

A rail approximately midway between the guardrail and platform, secured to the uprights erected along the exposed sides and ends of platforms.

Opening

Any space more than 30 inches high and 18 inches wide in a wall or partition, through which workers could fall to a lower level.

Overhand bricklaying

Bricklaying and masonry tasks requiring a mason to work while leaning over a wall.

Personal fall-arrest system

A conventional fall-protection system designed to stop a single worker from free falling to a lower level. Components include an anchor, connectors, a body harness, and may include a lanyard, deceleration device, or lifeline.

Platform

A temporary elevated working surface such as the floor of a scaffold.

Qualified person

A person who by possession of a recognized degree, certificate, or professional standing, or who by extensive knowledge, training and experience, has successfully demonstrated the ability to resolve problems relating to a specific subject, operation, or project.

Residential-type construction

Construction work on all types of structures, including commercial buildings, that are framed and covered with materials commonly associated with residential structures. Residential-type construction does not include tilt-up buildings, butler-type buildings, or large commercial structures.

Roof brackets and slide guards

Used in residential construction to prevent workers from sliding off a sloped roof.

Rope grab

A deceleration device that moves along a vertical lifeline; it automatically engages and locks on the lifeline when a worker falls.

Roof

The exterior surface on the top of a building. Does not include floors or form work which, if a building is not completed, temporarily become the top surface.

Roofing work

Includes hoisting, storing, applying, and removing roofing materials and equipment.

Safety factor

The weight ratio of a breaking load to safe load. For example, The anchor for a personal fall-arrest system be able to hold at least 5,000 pounds or it must be installed under the supervision of the qualified person and it must maintain a safety factor of at least two — two times the impact force of a worker free falling six feet.

Safety-monitoring system

A fall-protection system that requires a monitor (competent person) to be responsible for recognizing fall hazards and warning workers when they are at risk of falling.

Safety-net system

A fall-arrest system of mesh nets, including panels, connectors, and other impact-absorbing components.

Sag angle

A horizontal lifeline's angle of deflection when the line is subjected to a load.

Scaffold

Any temporary elevated platform and its supporting structure used for supporting workers, materials, or both.

Self-retracting lifeline/lanyard

A deceleration device consisting of a drum-wound line that retracts or extends from the drum with normal worker movements; in the event of a fall, the drum automatically locks. Self-retracting lifelines that automatically limit free-fall distance to two feet or less must have components capable of sustaining a minimum static tensile load of 3,000 pounds. Self-retracting lifelines that do not limit free-fall distance to two feet or less must be capable of sustaining a minimum tensile load of 5,000 pounds.

Snap hook

A connector, consisting of a hook-shaped member and a keeper that can be opened to receive an object and, when released, automatically closes to retain the object.

Swing fall

The pendulum motion that results when a worker using a personal fall-arrest system falls and swings back under the system's anchor point.

Tie off

The act of connecting to an anchor; tied-off means being connected to an anchor.

Tie-off adaptor/beam connector

Devices that anchor vertical lifelines or lanyards to I-beams and other objects with rough edges.

Toeboard

A low protective barrier that prevents materials, equipment, and personnel from falling to lower levels.

Vertical lifeline

A flexible vertical cable or rope line anchored at one end; the other end attaches to a worker's body harness, lanyard, or deceleration device. Each worker must be attached to a separate vertical lifeline. Vertical lifelines must have a minimum breaking strength of 5,000 pounds.

Walking and working surface

Any surfaces (except on ladders, vehicles, or trailers) on which workers perform tasks or jobs.

Warning-line system

A barrier erected on a roof to warn workers they are approaching an unprotected edge; designates an area for roofing work without conventional fall-protection systems (guardrail, safety net, or personal fall-arrest).

Work area

The portion of a walking/working surface where workers perform job tasks.

OR-OSHA services

OR-OSHA offers a wide variety of safety and health services to employers and employees:

Consultative Services

- Offers no-cost on-site safety and health assistance to Oregon employers to help in recognizing and correcting safety and health problems in their workplaces.
- Provides consultations in the areas of safety, industrial hygiene, ergonomics, occupational safety and health plans, new business assistance, and the Safety and Health Achievement Recognition Program (SHARP).

Enforcement

- Offers pre-job conferences for mobile employers in industries such as logging and construction.
- Provides abatement assistance to employers who have received citations and provides compliance and technical assistance by phone.
- Inspects places of employment for occupational safety and health rule violations and investigates workplace safety and health complaints and accidents.

Standards & Technical Resources

- Develops, interprets, and provides technical advice on safety and health standards.
- Provides copies of all OR-OSHA occupational safety and health codes.
- Publishes booklets, pamphlets, and other materials to assist in the implementation of safety and health codes and programs.
- Operates the OR-OSHA Resource Center containing books, topical files, technical periodicals, a video and film lending library, and more than 200 databases.
- Manages the Worksite Redesign Grant Program, which awards grants to develop and implement solutions to workplace safety, health, and ergonomic problems.

Public Education & Conferences

- Conducts conferences, seminars, workshops, and rule forums.
- Coordinates and provides technical training on topics like confined space, ergonomics, lockout/tagout, and excavations.
- Provides workshops covering basic safety and health program management, safety committees, accident investigation, and job safety analysis.
- Manages the Voluntary Protection Program and the Safety and Health Education and Training Grant Program, which awards grants to industrial and labor groups to develop occupational safety and health training materials for Oregon workers.

***For more information, call the OR-OSHA office nearest you.
(All phone numbers are voice and TTY.)***

Salem Central Office

350 Winter St. NE, Rm. 430
Salem, OR 97301-3882
Phone: (503) 378-3272
Toll free: 1-800-922-2689
Fax: (503) 947-7461
Spanish-language phone:
1 (800) 843-8086

Portland

1750 NW Naito Parkway, Ste. 112
Portland, OR 97209-2533
(503) 229-5910
Consultation: (503) 229-6193

Salem

1225 Ferry St. SE, U110
Salem, OR 97301-4282
(503) 378-3274
Consultation: (503) 373-7819

Eugene

1140 Willagillespie, Ste. 42
Eugene, OR 97401-2101
(541) 686-7562
Consultation: (541) 686-7913

Bend

Red Oaks Square
1230 NE Third St., Ste. A-115
Bend, OR 97701-4374
(541) 388-6066
Consultation: (541) 388-6068

Medford

1840 Barnett Rd., Ste. D
Medford, OR 97504-8250
(541) 776-6030
Consultation: (541) 776-6016

Pendleton

721 SE Third St., Ste. 306
Pendleton, OR 97801-3056
(541) 276-9175
Consultation: (541) 276-2353

